



PRODUCT CATALOGUE



Advanced Pipe and Roof
Heating Cable Systems
and Accessories

The Most Advanced Freeze Protection Systems in the World

Mission Statement:

The evenhanded operation of buying and selling is fundamental to the growth of all business. Over the years, companies have lost the sense for the importance of mutual respect between the people performing this exchange.

Truth, honesty and trust fuel our efforts toward our main objectives of developing advanced and reliable freeze protection systems while offering extraordinary expertise and communications in this field.

It is of great importance to maintain ongoing research and development to create new products to enhance lifestyle in the most severe cold climates. With complete understanding of the products we sell, outstanding efforts in direct communications between all parties and our common desire to always achieve higher standards, we will never lose sight of our customer's needs.

Lorne R. Heise & Robin Heise,
Co-Founders of Heat-Line



Table of Contents

Heat-Line Distributor Sales Proposition	1	Kompensator [®]	39
Why Heat-Line?.....	2	Features / Specifications / Applications	40
Self-Regulating Technology.....	3	About Kompensator.....	41
Electrical Connection Options	4	Product Codes & Accessories	42
Heat-Line System Features & Benefits.....	6	Paladin [®] for Roof	43
Retro-Line [®]	7	Features / Specifications / Applications	44
Features / Specifications / Applications	8	About Paladin for Roof	45
About Retro-Line	9	Product Codes & Accessories	46
Product Codes & Accessories	10	EDGE-CUTTER [®]	47
Retro-DWS [®]	11	Features / Specifications / Applications	48
Features / Specifications / Applications	12	About EDGE-CUTTER.....	49
About Retro-DWS	13	Product Codes & Accessories	50
Product Codes & Accessories	14	ArcticVent [®]	51
Retro-FM [®]	15	Features / Specifications / Applications	52
Features / Specifications / Applications	16	About ArcticVent	53
About Retro-FM.....	17	Product Codes & Accessories	54
Product Codes & Accessories	18	Cut-to-Length Heating Cable	55
Rizer-Line	19	General Heater Specifications	56
Features / Specifications / Applications	19	About Cut-to-Length Heating Cable.....	57
About Rizer-Line	20	Ordering Chart & Part Numbers	58
Product Codes & Accessories	22	Thermostats & Timers	59
CARAPACE [®]	23	Part Codes.....	60
Features / Specifications / Applications	23	Insulation	61
About CARAPACE	24	About Insulation / Part Codes / Accessories.....	62
Product Codes & Accessories	26	Philmac Fittings	63
Heat-Line [®]	27	About Philmac Fittings & Part Codes	64
Features / Specifications / Applications	28	MilliAMP	65
About Heat-Line	29	About MilliAMP / Part Codes / Accessories.....	66
Product Codes & Accessories	30	Surge-BLOK	67
Paladin [®] / EXT.....	31	About Surge-Blok & Fittings & Part Codes.....	68
Features / Specifications / Applications	32	The Heat-Line Team	69
About Paladin / EXT Series.....	33	Notes	69
Product Codes & Accessories	34		
Tandem-Link [®]	35		
Features / Specifications / Applications	36		
About Tandem-Link	37		
Product Codes & Accessories	38		

Intended use: This document is intended for recipient only as a shop copy. Commercial distribution not permitted. All information, including illustrations, is believed to be reliable. Users, however, should independently evaluate the suitability of each product for their particular application.

For conversions to metric system:

Meters	m	=	ft x 3.28
Watts/Meter	w/m	=	w/ft x 3.28
Degrees Celsius	°C	=	(°F – 32) x 0.55

ATTENTION:

Heat-Line manufactures other innovative products including OEM products that are not mentioned in this catalogue. Visit www.heatline.com for more information.



In-Pipe Water Supply

Pg 7



In Pipe Sewer and Drains

Pg 11



In-Pipe Sewer and Large Water Supply

Pg 15



Rizer-Line

Rural and Municipal Water Supply Pipe

Pg 23



Rural Water Supply Pipe

Pg 27



On-Pipe and In-Pipe Drains

Pg 31



On-Pipe Inter-Connecting

Pg 35



On-Pipe Low Voltage

Pg 39



Roof and Gutter De-Icing Heating Cable

Pg 43



Advanced Roof Edge De-Icing Systems

Pg 47



Freeze Protected Plumbing Vents

Pg 51



Cut-to-Length Heating Cable

Pg 55



Thermostats and Timers

Pg 59



Pipe Insulation

Pg 61



ELCI / GFCI

Pg 63



ELCI / GFCI

Pg 65



Surge-BLOK

Pg 67



Heat-Line Distributor Sales Proposition

Contractors Face This Scenario Every Winter and Summer

With post-freeze repairs of existing water pipes after winter and new construction in summer, plumbing contractors are tasked to repair/replace fluid pipes and protect them from freezing. Over many years, various methods have been used. Some fail and some are successful, but never before have complete and proven systems been offered to the trades. Reliable systems that are designed and engineered to efficiently and safely resolve age-old freezing problems. Heat-Line invents, develops, manufactures and offers simple state-of-the-art systems that are a pleasure to install.

Traditional heating cable or hardware store heat tapes are the most common fix seen in the industry today. Often incorrectly installed and inexpensive to purchase, these systems can fail when traditional winters hit hard. For lack of a better way, these old systems are often found installed in situations and places far beyond their intended use, making safety an ongoing concern.

When a service call is required, each trade has its own specialty; plumbers are not electricians, and electricians are not plumbers. The result is expensive cross-trade service calls by the plumbing and electrical contractors. This always leads to heavy co-ordination expenses and costly delays.

In new construction projects, freeze protection is often specified in this manner, where the plumbing specification calls for the plumbing/mechanical contractor to buy the heating cable, and the electrical specification calls for electricians to design, install and connect the system. The plumbing/mechanical contractors must then return and insulate. Three installation processes for a single installation. This not only delays the installation but also introduces confusion regarding who is ultimately responsible for the installation and warranty.

Heat-Line systems remove the guess work and are engineered for the purpose of protecting pipes in the harshest environments. Heat-Line systems require no specialized terminations or testing. Every system is tagged, tested and factory certified to the high standards of North American regulatory agencies such as CSA and NSF.



Heat-Line Systems Provide a Value Advantage for Plumbing/Mechanical Contractors

Heat-Line freeze protection systems can be ordered ground fault protected, are designed to be installed by plumbing/mechanical contractors and meet requirements of CSA c-us for North America. The systems simply plug in. In addition, our internal pipe freeze protection systems are often installed in as little as 15 minutes. No electrical work is required, which allows plumbing/mechanical contractors to become a sole source solution for their customers.

Heat-Line systems are constructed with the highest quality self-regulating/conductive polymer, auto-therming heating cables and components. This allows contractors to safely insulate metallic or non-metallic (plastic) pipes. This ability to insulate greatly reduces energy costs compared with any other system on the market today.

IMPORTANT

Waterworks, mechanical and plumbing distributors can offer solutions to industry pipe freezing problems with Heat-Line Systems.

Why Heat-Line?

Innovation

Multiple patents for advanced freeze protection systems with a continuing effort to identify cold climate problems and resolve them with new industry-leading products, designed uniquely by tradespeople for installation by the trades.

Safety and Standards

Heat-Line is an industry leader in cutting-edge products that meet or exceed regulatory standards. Heat-Line products are certified by governing authorities such as CSA and NSF to meet rigid North American standards.

Research & Development

Heat-Line continually conducts new product development at their on-site Research and Development facility.

Heat-Line Designs and Tests in a Natural Laboratory

Corporate facilities are located in the harsh, cold and rocky environment of Haliburton, Ontario, Canada. Heat-Line's business operations are located on the Precambrian Shield where temperatures can reach -40°F and it is rare to excavate below the frost line.

Real World Installation

Heat-Line was founded by a licensed, practicing electrician in 1988. All products are built from the tradesperson's point of view, and meticulous consideration is given to the installation requirements of every product design. Quality of materials are paramount and only the finest are used. Heat-Line products can be found protecting pipes as far north as Eureka in Nunavut, Canada, and as far south as Antarctica.

Industry-Leading Knowledge

Since 1988 Heat-Line has maintained successful continuous operation and company growth. Company staff have expanded to include tradespeople, scientists, engineers, sales technicians, support staff and administration personnel. Heat-Line is an award winning company that constantly stays in touch with cold climate needs by always developing new products.

Manufacturing

All systems are manufactured and assembled in North America (Canada and the United States) using North American made raw materials.



Heat-Line Self-Regulating Heating Cables

All Heat-Line products are self-regulating. The benefit of self-regulating is that unlike constant wattage heaters, there is no concern about underheating or overheating, even when insulated.

Heat-Line products offer cost-effective operation and maintenance reliability. The unique, self-regulating technology enables each Heat-Line product to vary its power output in response to temperature at every point along its length. As the temperature increases, Heat-Line products automatically decrease their heat output, and vice versa. The result is energy savings; the heating cable decreases heat when not required and rapidly increases heat when and where necessary. Heat-Line systems continually compensate for temperature fluctuations.



How Self-Regulating Technology Works

All Heat-Line heating cables are specially blended combinations of polymer and conductive carbon that create electrical paths between parallel buss wires at every point along their circuit. As the surrounding ambient temperature (water or air) cools, the heater core contracts microscopically. This contraction decreases resistance and increases power output. The resulting increase in power output – and thus heat – compensates for installation variables.

As the heating cables warm, the cores expand microscopically, resulting in reduced power output. The reduced power output minimizes operating energy costs and eliminates maintenance costs due to hot spots or burnout's. Heat is applied safely and efficiently when and where needed.

Heating Cable Construction And Operation

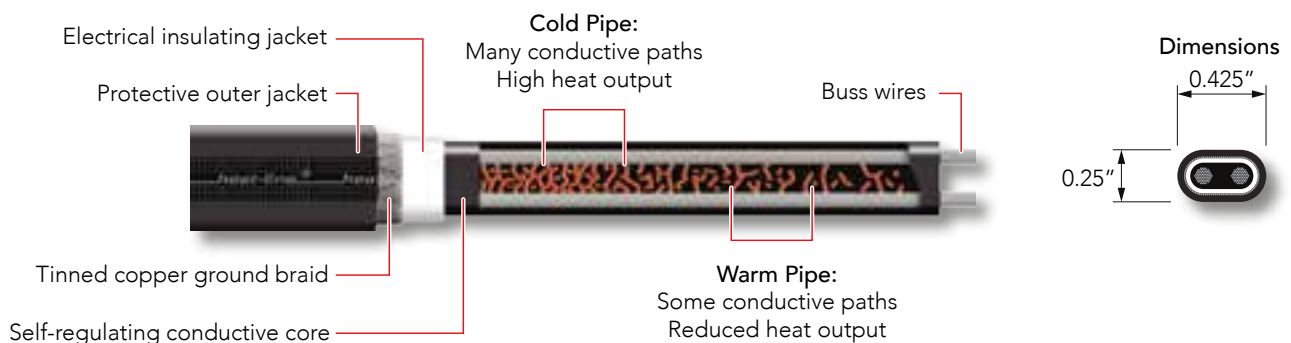

Energy Consumption Case Study

A question commonly asked is '**what will it cost to operate my Heat-Line system?**' There is no exact answer as the self-regulating heating cable technology allows the heat (watt) output to adjust microscopically along the heating cable length depending on surrounding temperatures. See the Heat-Line Self-Regulating Heating Cables section (P. 3) for more about Heat-Line's technology. Every application is different and is exposed to different temperatures. What we do know is how efficient your system operates depends a lot on the installation. Use pipe insulation wherever possible and use a control device such as a thermostat and/or timer.

Below is a case study of a real life application provided to help you understand the energy efficiency of Heat-Line systems. This study was completed with a CARAPACE system which employs similar technology to any Heat-Line heating cable system.



LOCATION

- Carnarvon, ON, CANADA
- 45°02'43"N | 78°41'53"W
- 1,090 ft elevation (above sea level)



PROPERTY

- 30 - 40 ft elevation (above lake level)
- Rock terrain, rock shoreline



PRODUCT

- CARAPACE, 1" Rural (ID controlled), 240 volt, 5w @ 50°F
- System length; 270 feet (90 on land, 180 in the lake)
- (90 feet) of pipe insulation on land
- No pipe insulation in lake
- Thermostat in use at 50°F (10°C)
- Sensor location 45 ft from building on pipe under insulation (coldest point)



LAKE

- Sand lake bed, no obstructions
- 4 foot water depth at 110 ft from shoreline
- 10 foot water depth at 150 ft
- 20 foot water depth at 170 – 180 ft from shoreline



DURATION

- CARAPACE powered on November 10, 2007
- CARAPACE powered off April 25, 2008
- 70 days recorded temperatures

TEST RESULTS

167 Days of Total Operation

Total Cost \$91.05

Coldest recorded temp.	-27.4°F (-33°C)
Warmest recorded temp.	48.2°F (9°C)
Average temp.	17.7°F (-8°C)
Kilowatt usage	1,821 kW/h
Price per kw/h (April 2008)	\$0.05
Total Cost	\$91.05

***Disclaimer:** Energy consumption will change depending on product selection, application, location and climate. This case study should be used as an example only, but exemplifies the high performance capability of the product.

Electrical Connection Options GFC vs CS

All Heat-Line brand heating cable systems are available in 120 or 240 volts and have the option to have either a GFC (ground fault protected, plug-in) or CS (cord set, hard wire). The only exception is Kompensator which is low voltage, 12 or 24 volts and available in CS only. When no electrical connection option is stated on an order GFC is always the default unless accessories are also ordered requiring the CS option for proper connection.

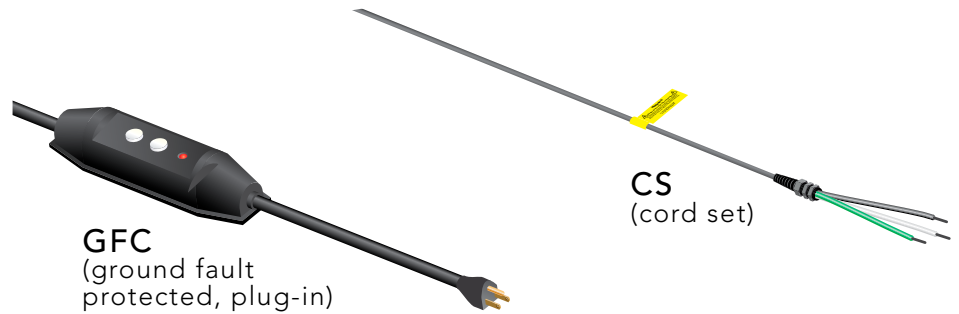

Note: (GFC may not always be supplied as shown)

GFC

Ground fault protected with an integral 27 milliamp ELCI which plug into a standard 120 volt or 240 volt receptacle. We recommend the use of specification grade receptacles (CSA 5-15R for 120 volt) and (CSA 6-15R for 240 volt). Cording is #14 or #12 SJEOOW depending on system length.

Ground fault protected systems are ordered with a suffix – “GFC” after the product number.

CS

Cord-Set only, the product is supplied with a 6 foot long #14 or #12 SJEOOW cord depending on system length, with a 6 inch knock-out strain relief fitting. Ground fault circuit protection must be field installed with these systems. These systems are also used when the systems are installed with our GFA-STAT which is a Nema 4X thermostat with integral 30 milliamp GFEP or other accessories requiring a hard wire connection.

Cord-Set systems are ordered with a suffix – “CS” after the product number.

Note: The CEC (Canadian Electrical Code) and the NEC (National Electrical Code – USA) require ground fault equipment protection on all heating cable systems.

Heat-Line System Features & Benefits

All Heat-Line heating cable products are self-regulating, offering cost-effective operation and maintenance reliability. Specially blended combinations of polymer and conductive carbon create a unique heating cable product advantage that no traditional heat tape can equal. There is no concern of under and or overheating. Whether for the rural home and cottage, industrial and commercial facilities, transportation industry, farms and agriculture and or temporary mines and discovery camps; Heat-Line pipe products provide reliable protection where freezing temperatures can cause serious damage to expensive and necessary equipment. Customers rely on Heat-Line's exceptional freeze protection systems and heating cable to keep water and other liquids flowing in extreme climates and circumstances. As you review the Heat-Line product group, you will see the unique style and engineering that is employed in every design.

Below is a list of Features and Benefits found in every Heat-Line system.

- cCSAus approved (Canada and USA) LR85446
- Self-Regulating/ conductive polymer heating cable
- Standard wattages 3, 5, 8 watts/foot at 50°F
- Systems available in 120V and 240V, 12V and 24V
- Customs lengths available
- Available with either GFCI plug or CS hard wire connection (120V and 240V)
- Engineered proprietary end seal technology
- Standard warranty of 5 yrs with optional 10 yrs (most 120V and 240V systems)
- Factory finished, job-ready – no liability for connections
- Each finished system is tested prior to shipment
- Single trade installation where a receptacle is within reach
- Manufactured to finished lengths for individual service requirements
- Suitable for installation with plastic or metal pipes
- Can be fully insulated to maximize energy efficiency
- Unlimited optional control devices such as thermostats and timers
- Thermostats not required for applications where they are not beneficial
- Will never melt or overheat, even if pipe is dry
- Extremely energy efficient
- Proven, reliable, installations successful over 30 years
- Manufactured in North America
- Clear, concise installation and support documentation
- Quick turnaround time
- Best warranty in the business
- Extremely high quality, consistent product, top quality control procedures
- Fully backed and supported; Heat-Line offers technical advice and assistance



Retro-Line®

Leading Advanced Internal Water Supply Pipe Freeze Protection Systems.

Retro-Line is a job-ready freeze protection kit designed to be installed in minutes inside existing water supply pipes from 3/4" to 2" of many piping materials.



Features & Benefits

- The only manufactured, self-regulating heating cable for in-pipe applications
- Multiple plumbing fittings available – Tees in ID-IPS, CTS and OD-IPS sizes, MIPT threads in 1 inch to 2 inch sizes
- Available in a plug-in GFCI model or hard wire cord-set model depending on application
- Completely customizable for various application requirements
- Length can be adjusted (shortened) on the job-site by means of extracting the cable through plumbing fitting (contact Heat-Line for guidance)
- Available in common lengths and long lengths
- Suitable for pipe diameters 3/4 inch to 2 inch, for larger pipe diameters see Retro-FM
- Withstands water pressure up to 230 PSI
- Suitable for installation in plastic or metal pipes
- Can be installed into existing pipes without excavation
- Can be pushed in most pipes up to 150 feet
- Long systems can be drawn in with fish tape or twine
- Lengths 40 feet and greater are supplied on a dispensing reel for ease of installation
- Heating cable is rigid enough to stay in place within the entire length of pipe, no downward fastening device
- Fully serviceable, can easily be removed if necessary
- Suitable for above ground applications with insulation
- Suitable for sump pump lines
- Will never melt or overheat, even if pipe is dry
- Proven in -40°F weather above ground with 3/4 inch polyethylene insulation

For more Features and Benefits common amongst all Heat-Line brand systems refer to page 6.

Specifications

- cCSAus approved (Canada and USA) LR85446
- NSF/ANSI 61 Drinking Water Safe
- Approved for potable drinking water
- Certified Usage Type P and X Canada
- Installation Type D USA
- Self-Regulating/ conductive polymer heating cable
- Fluoropolymer outer jacket
- Standard wattage 3 watts/foot at 50°F, special wattage available
- Available in 120V and 240V
- Max lengths 120V - 230 ft, 240V - 550 ft
- Available with either GFCI plug or CS hard wire connection
- Proprietary end seal technology engineered for applications up to 230 PSI
- Standard warranty of 5 yrs with optional 10 yrs

Applications

- Existing water supply lines subject to freezing
- Rural home and business water supply systems
- Sump pump lines
- Lake homes and cottages / cabins
- Wells
- Farms, agriculture / commercial, industrial / construction sites
- Camps / mining
- Lake/river source waterline
- Certain municipal water supplies





Internal Water Supply Freeze Protection

Retro-Line is an internal self-regulating heat tracing system designed to provide freeze protection of existing water supply and fluid pipes without their removal. Insulation and an optional thermostat can be used to optimize energy efficiency.

CSA/NSF Approved

Retro-Line is the only cCSAus NSF/ANSI 61 Drinking Water approved, internal self-regulating P and X factory finished freeze protection system available on the market.

Complete System

The Retro-Line system is supplied in a predetermined length with all necessary components for a complete system. For polyethylene pipe applications Retro-Line is supplied with a compression fitting for connection to the pipe.

Multiple Interfacing

An I.D. controlled tee fitting for polyethylene pipe is supplied standard with the Retro-Line system. Retro-Line can also be ordered with a CTS controlled tee or a threaded male adapter for easy interfacing to pipe such as ABS, PVC, PEX, copper, galvanized and steel.

Requirements

Retro-Line orders require the length of heating cable and pipe size for polyethylene installations or male adapter thread size for other pipe installations. System lengths are 120 volt up to 230 feet and 240 volt up to 550 feet. Minimum pipe size required is 3/4 inch ID.

Fully Servicable

Short Retro-Lines can simply be pushed into the pipe while longer systems may be pulled in using a fish tape. The downward end of the cable does not need to be internally fastened, as it will not re-coil, which is extremely important as it renders the system fully serviceable. The system can be removed and replaced should it become necessary.

Easy Installation

Heat-Line developed a unique, patented dispensing system called "Retro-Reel" to protect the heating cable and fittings from mechanical injury while the product is deployed into the pipe with absolute ease. It is not unusual to push systems in up to 150 feet and sometimes more.

Versatile Application

Retro-Line can be used in a variety of applications, including metal and plastic water supply, sump pump lines and pressurized or high volume drain pipes.

Retro-Line | Product Code

Example: **RL - 125 - 100 - CTS - GFC**

Product	RL 120 volt Retro-Line RL2 240 volt Retro-Line	Cord-Set Type	GFC Ground fault protected 5-15P 120V / 6-15P 240V CS Cord connected (No GFCI)
Fitting/Pipe Size	075 Fitting/Pipe Size 3/4" * 100 Fitting/Pipe Size 1" 125 Fitting/Pipe Size 1 1/4" ** 150 Fitting/Pipe Size 1 1/2" 200 Fitting/Pipe Size 2" ***	Fitting Type	ID Internal pipe diameter IS-IPS tee fitting CTS Copper tubing size CTS tee fitting OD Outside pipe diameter OD-IPS tee fitting IP Male Adapter (thread size) MIPT fitting NI 1" and 1.25" kit internal pipe diameter ID tee
	* Not available in IP ** NI fitting type must chose 125 *** Not available in CTS	Length of Heater	6 - 230 feet 3 watt /120V systems 6 - 550 feet 3 watt /240V systems

NOTE: The heating cable is measured and cut to the length of system ordered. Some of this length will remain within the interface fitting.

Retro-Line | Accessories

Product Code	Description
HLA-120	120V plug-in thermostat (GFC)
GFA-STAT	120/240V hard wire thermostat with GFEP (CS)
TIMER-120P	120V plug-in timer (GFC)
TIMER-240P	240V plug-in timer (GFC)
TIMER-CS	120/240V hard wire timer (CS)
MA-10	120/240V GFCI/ELCI (CS)
INSUL-1.00	Insulation sleeve for 1 inch ID pipe (1 5/8 inch ID, 6 ft long)
INSUL-1.25	Insulation sleeve for 1 1/4 inch ID pipe (1 7/8 inch ID, 6 ft long)
INSUL-2.00	Insulation sleeve for 2 inch ID pipe (2 5/8 inch ID, 6 ft long)
HLP-TAPE	Tape for insulation sleeve butt joints (100 ft)
WARRANTY	Extended 10 year limited warranty

Retro-Line | Sample Installation

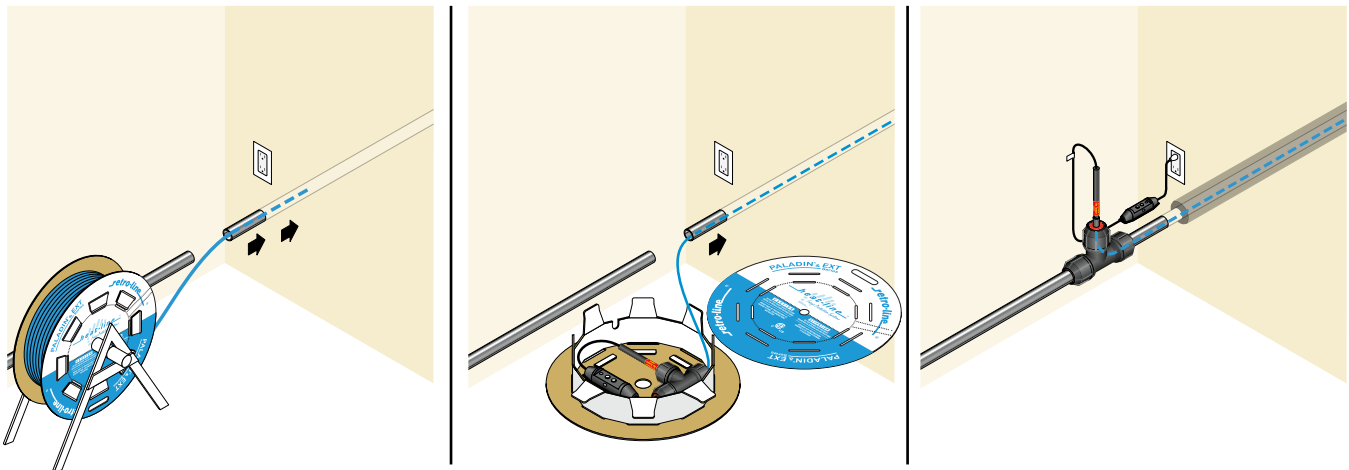

Retro-DWS[®]

Internal Tubular Freeze Protection System for Non-Pressurized Drain, Waste and Sewer Pipe Applications.

Retro-DWS (Drain Waste Sewer) supplied job-ready to internally heat trace common 3 inch and 4 inch septic and sewage pipe applications. The product can be easily adapted to a variety of drainage pipes and fit larger sized septic, storm drain and sewage pipes by using readily available components.



Features & Benefits

- The only in-pipe system designed specifically for grey and black water applications
- Factory finished, job-ready – no liability for installer
- Each finished system is tested prior to shipment
- Single trade installation where a receptacle is within reach
- Manufactured to finished lengths for individual service requirements
- Multiple plumbing fittings supplied to adapt to 3 inch and 4 inch ABS clean-outs
- Available in a plug-in GFCI model or hard wire cord-set model depending on application
- Completely customizable for various application requirements
- Length can be adjusted (shortened) on the job-site by means of extracting the cable through plumbing fitting
- Available in common lengths and long lengths
- Suitable for pipe diameters 3 inch and larger
- Suitable for non-pressurized pipe, for pressurized systems see Retro-FM
- Suitable for installation in plastic or metal pipes
- Can be installed into existing pipes without excavation
- Can be pushed in most pipe up to 150 feet
- Long systems can be drawn in with fish tape or twine
- Fully serviceable, can be removed if necessary
- Suitable for above ground applications with insulation
- Will never melt or overheat, even if pipe is dry
- Heating cable is protected within 1/2 inch HDPE pipe

For more Features and Benefits common amongst all Heat-Line brand systems refer to page 6.

Specifications

- cCSAus approved (Canada and USA) LR85446
- Certified Usage Type W Canada
- Installation Type D USA
- Internal waste (grey and black) water certified
- Self-Regulating/ conductive polymer heating cable
- Tubular Heater (heating cable installed inside HDPE polyethylene)
- Standard wattage 5 watts/foot at 50°F, special wattage available
- Available in 120V and 240V
- Max lengths 120V - 230 ft, 240V - 540 ft
- Available with either GFCI plug or CS hard wire connection
- Standard warranty of 5 yrs with optional 10 yrs

Applications

- Existing fresh water drains, storm drains and sewer subject to freezing
- Rural homes, cottages, farms
- Commercial, industrial, municipal
- Storm drains under parking lots
- Storm sewers, sewers, culverts
- Camps, mining
- Wherever blasting would be required to reach frost line





Internal Tubular Freeze Protection

Retro-DWS is an internal tubular heating cable system designed to provide freeze protection for existing problematic drains, sewers and culverts without the need to excavate. Insulation and thermostatic control can be added to optimize energy efficiency as required.

Complete System

The Retro-DWS is constructed with Heat-Line certified, self-regulating heating cable systems, factory installed inside a 1/2 inch HDPE tube with a factory applied fusion end-seal. The system is manufactured to a predetermined length and is supplied complete with all necessary plumbing components. The components supplied interface with 3 inch and 4 inch ABS pipes using an existing or installed clean-out, Tee or Wye as an access point. If required, the Retro-DWS can be easily adapted to fit larger pipe diameters by using readily available, industry standard components.

Interface Versatility

The versatile interface process of the Retro-DWS makes the system suitable for installation in pipe diameters from 3 inches to greater than 8 inches. In larger pipe applications, Retro-DWS is designed to provide a melt-water path, thus allowing continuous flow through the entire channel. This allows the fluids to carve their way through large diameter culverts or drains without having to install energy-expensive high watt density heat cables.

Will Not Overheat

The self-regulating heating cable technology renders the system safe to use in all metal and non-metal pipes. Even if the pipe is dry, the self-regulating heating cable presents no danger of overheating, making it suitable for drain lines that do not always contain liquids.

Retro-DWS is the only heating cable system designed to protect drain, storm drain, culvert, waste and sewer systems. These include but are not limited to septic tanks, holding tanks and other similar applications. Retro-DWS can be used as a system to prevent freezing or as a precautionary system to use only if a freeze-up occurs.

Fully Serviceable

The Retro-DWS is a fully serviceable product. If a blockage occurs, the entire heat system can be removed and re-installed.

Requirements

When ordering Retro-DWS you will need to know the length of heating cable that is required. System lengths are 120 volt up to 230 feet and 240 volt up to 300 feet. Longer systems are available by special order. Minimum pipe size required is 3 inch ID.

Important Considerations

Retro-DWS defends against many various and difficult freezing processes and conditions. The use of his product and its compatibility with a particular application is at the complete discretion of the user. The possibility exist that this product may cause an obstruction, especially where foreign objects or solids may flow in direct contact with it. A service schedule is recommended.

Retro-DWS | Product Code

Example: **DWS - 5 - 100 - GFC**

Product

DWS 120 volt (100-130 volt) Retro-DWS
 DWS2 240 volt (208-277 volt) Retro-DWS

Wattage

5 5 watts self-regulating heater (standard)
 8 8 watts self-regulating heater

Cord-Set Type

GFC	Ground Fault Protected	CS Cord Connected (No GFCI)	
		Max length	Max length
5 watt / 120 volt	230 ft	230 ft	Note: Installers must provide 20 Amp circuits for CS circuit lengths greater than 460ft for 5 watt and 300 ft for 8 watt systems.
8 watt / 120 volt	150 ft	150 ft	
5 watt / 240 volt	460 ft	540 ft	
8 watt / 240 volt	300 ft	400 ft	

Length of Heater

Retro-DWS | Accessories

Product Code	Description
HLA-120	120V plug-in thermostat (GFC)
GFA-STAT	120/240V hard wire thermostat GFEP (CS)
TIMER-120P	120V plug-in timer (GFC)
TIMER-240P	240V plug-in timer (GFC)
TIMER-CS	120/240V hard wire timer (CS)
MA-10	120/240V GFCI/ELCI (CS)
INSUL-3.00	Insulation sleeve for 3 inch ID pipe (3 1/2 inch ID, 6 ft long)
INSUL-4.00	Insulation sleeve for 4 inch ID pipe (4 1/2 inch ID, 6 ft long)
HLP-TAPE	Tape for insulation sleeve butt joints (100 ft)
INSUL-FOIL	Aluminum bubble foil insulation (16 in wide, sold by the foot)
INSUL-TAPE	All weather Aluminum foil tape (150 ft)
TORQ-60	No hub torque wrench automatic release at 60 IN. LB.
WARRANTY	Extended 10 year limited warranty

Retro-DWS | Sample Application

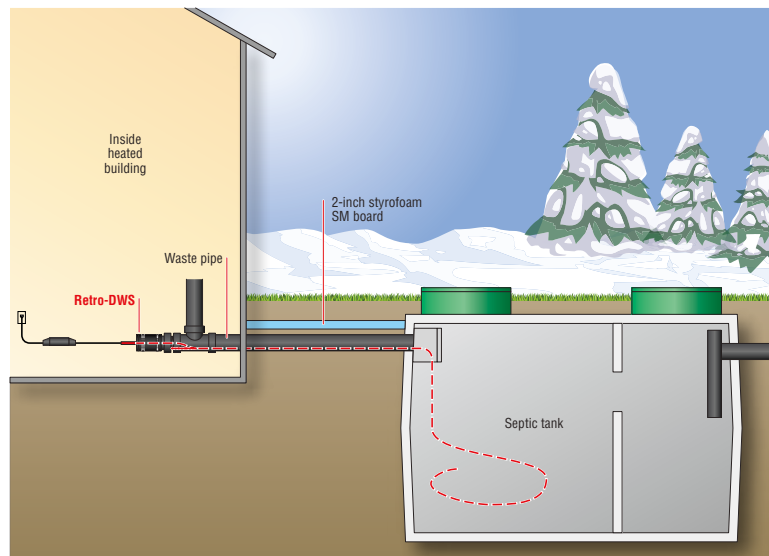

Retro-FM[®]

Internal Tubular Freeze Protection System for Pressurized Sewage, Force Main and Large Diameter Potable Pipe Applications.

Retro-FM (Force Main) self-regulating heating cable systems are supplied job-ready to internally heat trace pressurized sewage force main applications. Retro-FM can be easily adapted to a variety of pipes and can also be interfaced to larger diameter potable pipes by using readily available bushings and fittings.

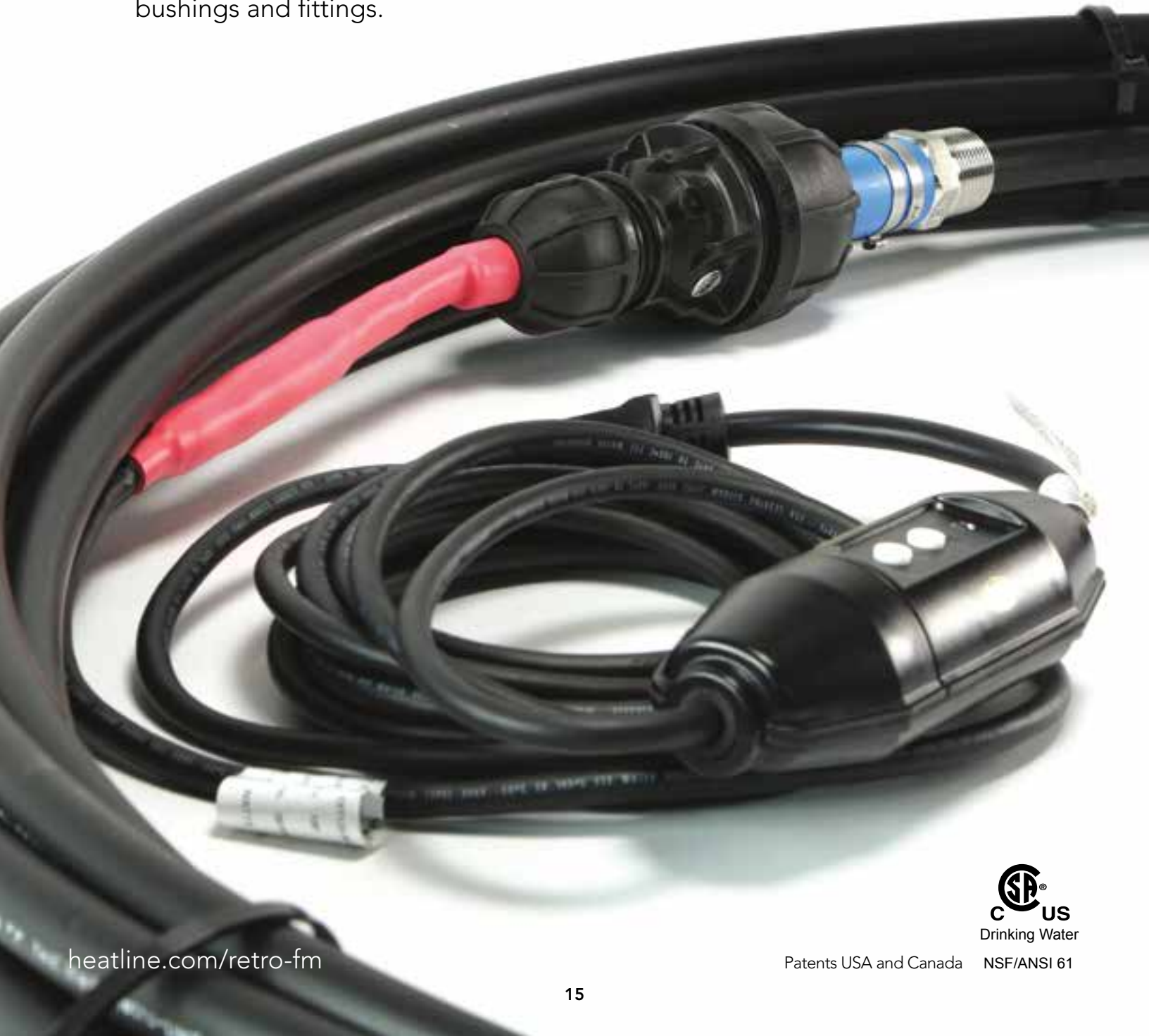

Features & Benefits

- The only in-pipe system designed for grey/black water and potable water applications
- Multiple fittings supplied – 1 inch stainless steel MIP staged fitting for connection and 1 inch FIP X 2 inch MIP PVC reducing bushing
- Available in a plug-in GFCI model or hard wire cord-set model depending on application
- Completely customizable for various application requirements
- Available in common lengths and long lengths
- Suitable for pipe diameters 2 inch and larger
- Withstands water pressure up to 230 PSI
- Suitable for installation in plastic or metal pipes
- Can be installed into existing pipes without excavation
- Can be pushed in pipe up to 150 feet
- Long systems can be drawn in with fish tape or twine
- Fully serviceable, can be removed if necessary
- Can be fully insulated to maximize energy efficiency
- Suitable for above ground applications with insulation
- Will never melt or overheat, even if pipe is dry

For more Features and Benefits common amongst all Heat-Line brand systems refer to page 6.

Specifications

- cCSAus approved (Canada and USA) LR85446
- NSF/ANSI 61 Drinking Water Safe
- Approved for potable drinking water
- Certified Usage Type P and X Canada
- Installation Type A USA
- Self-Regulating/ conductive polymer heating cable
- Tubular Heater (heating cable installed inside HDPE polyethylene)
- Standard wattage 5 watts/foot at 50°F, special wattage available
- Available in 120V and 240V
- Max lengths 120V - 230 ft, 240V - 540 ft
- Available with either GFCI plug or CS hard wire connection
- 20 foot power supply lead
- End seal termination certified to pressures up to 230 PSI
- Standard warranty of 5 yrs with optional 10 yrs

Applications

- Rural homes, cottages, farms, commercial, industrial, municipal
- Storm drains under parking lots
- Storm sewers
- Sewers, Sewage force mains
- Camps, mining
- Wherever blasting would be required to reach frost line





Internal Tubular Freeze Protection

Retro-FM is a tubular self-regulating heating system designed for use in pressurized sewage and greywater force mains and large diameter pressurized potable water pipes.

CSA/NSF Approved

Retro-FM is cCSAus NSF/ANSI 61 Drinking Water approved, usage P and X. The core tube is constructed of HDPE (high density polyethylene) and will push inside most pipes for long distances. It can also be drawn in with a fish tape or rope. Retro-FM utilizes a conductive polymer tubular heater technology, which provides a barrier from fluids while providing extremely efficient freeze protection.

Protects Potable Water Pipes

Retro-FM is designed to protect many large pressurized pipe systems that contain fluids that are compatible to be in contact with polyethylene, including potable water pipes. Retro-FM (Force Main) self-regulating heating cable systems are supplied job-ready to internally heat trace pressurized sewage force main applications. Retro-FM can be easily adapted to a variety of pipes and can also be interfaced to larger diameter potable pipes by using readily available bushings and fittings.

Compatible for All Pipes

The system is compatible for use with all pipe types, including metal and non-metal. Even if the pipe is dry, the tubular heater presents no danger of overheating even when thermally insulated. This is very important for use in pipes that drain back or are periodically dry.

Customization

Retro-FM employs Heat-Line's self-regulating technology applied within a factory assembled, fusion sealed HDPE tube. The systems are custom manufactured to specified lengths and come with a 20 foot SJEOOW hard usage cord-set, with or without integral ground fault circuit protection.

Job Ready to Quickly Interface Fittings

Retro-FM is supplied job-ready with a 1 inch stainless steel MIP staged fitting to quickly interface into force main tee or wye fittings. The product can be used in a variety of applications.

Prevention or Precaution

Retro-FM can be used as a system to prevent freezing or as a precautionary system. If the system freezes, Retro-FM can be energized to begin the thawing process.

No Need to Excavate

Retro-FM provides freeze protection for existing problematic pipes without the need to excavate. Insulation and thermostatic controls can be added to optimize energy efficiency as required.

Retro-FM | Product Code

Example: **FM - 5 - 100 - GFC**

Product	Description	Cord-Set Type		Length of Heater	Note
		GFC Ground Fault Protected	CS Cord Connected (No GFCI)		
FM	120 volt Retro-FM				Note: Installers must provide 20 Amp circuits for CS circuit lengths greater than 460 ft for 5 watt and 300 ft for 8 watt systems.
FM2	240 volt Retro-FM				
Wattage	5	5 Watt, TPR heater jacket			
	8	8 Watt, TPR heater jacket			
			Max length	Max length	
		5 watt / 120 volt	230 ft	270 ft	
		8 watt / 120 volt	150 ft	200 ft	
		5 watt / 240 volt	460 ft	540 ft	
		8 watt / 240 volt	300 ft	400 ft	

Retro-FM | Accessories

Product Code	Description
HLA-120	120V plug-in thermostat (GFC)
GFA-STAT	120/240V hard wire thermostat with GFEP (CS)
TIMER-120P	120V plug-in timer (GFC)
TIMER-240P	240V plug-in timer (GFC)
TIMER-CS	120/240V hard wire timer (CS)
MA-10	120/240V GFCI/ELCI (CS)
INSUL-2.00	Insulation sleeve for 2 inch ID pipe (2 5/8 inch ID, 6 ft long)
INSUL-3.00	Insulation sleeve for 3 inch ID pipe (3 1/2 inch ID, 6 ft long)
INSUL-4.00	Insulation sleeve for 4 inch ID pipe (4 1/2 inch ID, 6 ft long)
HLP-TAPE	Tape for insulation sleeve butt joints (100 ft)
INSUL-FOIL	Aluminum bubble foil insulation (16 in wide, sold by the foot)
INSUL-TAPE	All weather Aluminum foil tape (150 ft)
WARRANTY	Extended 10 year limited warranty

Retro-FM | Sample Rural Septic Application

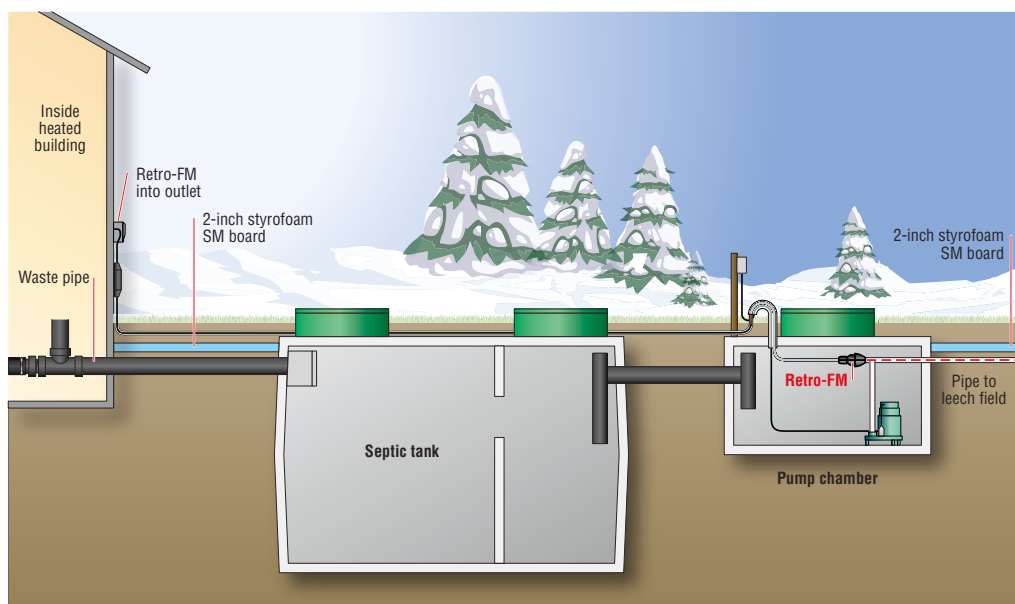

Rizer-Line™

The preferred heating cable solution for preventing automatic water bowls from freezing.

Rizer-Line is a job-ready freeze protection kit designed to be installed with existing automatic water bowls to supply reliable and safe drinking water.



Features & Benefits

- The only heating cable system designed specifically for automatic water bowls
- Plumbing fitting included – 1 inch MIPT thread
- Available in a plug-in GFCI model or hard wire cord-set model depending on application
- In-Pipe length can be adjusted (shortened) on the job-site by means of extracting the cable through plumbing fitting
- Suitable for installation in pipe diameters ¾ inch and larger
- Suitable for installation in/on plastic and metal pipes
- Fully serviceable, can easily be removed if necessary
- Can be fully insulated to maximize energy efficiency
- Suitable for above ground applications with insulation
- Will never melt or overheat, even if pipe is dry
- Can be overlapped without concern of overheating
- Proven in -40°F weather above ground with 3/4 inch polyethylene insulation

For more Features and Benefits common amongst all Heat-Line brand systems refer to page 6.

Specifications

- cCSAus approved (Canada and USA) LR85446
- NSF/ANSI 61 Drinking Water Safe
- Approved for potable drinking water
- Certified Usage Type P and X Canada
- Installation Type D USA
- Self-Regulating/ conductive polymer heating cable
- Fluoropolymer outer jacket
- Standard wattage 3 watts/foot at 50°F
- Available in 120V and 240V
- 10 feet of in-pipe heater and 2 feet of on-pipe heater
- Available with either GFCI plug or CS hard wire connection
- Standard warranty of 5 yrs with optional 10 yrs

Applications

- Anywhere automatic livestock watering bowls require freeze protection





Complete System

Rizer-Line is the preferred heating cable solution for preventing automatic water supply bowls from freezing.

All In One System

Rizer-Line is a complete kit designed to internally freeze protect the water supply pipe coming up to the bowl and externally freeze protect the small pipes within the bowl casing itself.

Safe For Livestock

Rizer-Line is safe to use in/on all pipe materials including plastic. The self-regulating technology ensures it will never overheat and melt. The GFCI prevents risk of shock to animals if the heating cable were to ever sustain damage.

CSA/NSF Approved

Rizer-Line has been through the strictest tests by CSA and NSF to prove it is safe to use in drinking water. We understand the animals deserve the best, clean water without harmful toxins.

Easy Installation

Simple, effective design for ease of installation. Supplied with everything you need to have the system operational; factory terminated heating cable, plumbing fitting and either choice of plug-in with GFCI or hardwire. Install 10 feet of heater inside the supply and the remain 2 feet on the external pipes and under the water bowl.

Will Not Overheat

Manufactured using North American self-regulating heating cable which adjusts its heat output based on surrounding temperatures. It can never overheat, even on plastic pipes or if the pipe is dry.

Requirements

Can interface into any supply pipe 3/4 inch ID or larger and protect any size pipes or tubes within the bowl casing itself. Can be supplied in 120 or 240 volt. As a plug-in unit with GFCI protection or as a direct hard wire unit.

Fully Serviceable

The Rizer-Line can easily be removed and re-installed if ever necessary.

Emergency Systems

Can be installed as a precautionary system to only be energized if a freeze up occurs. It will easily, safely and quickly melt and clear frozen water pipes.

Energy Efficient

Complete product is rated at only 36 watts, self-regulating.

Rizer-Line | Product Code

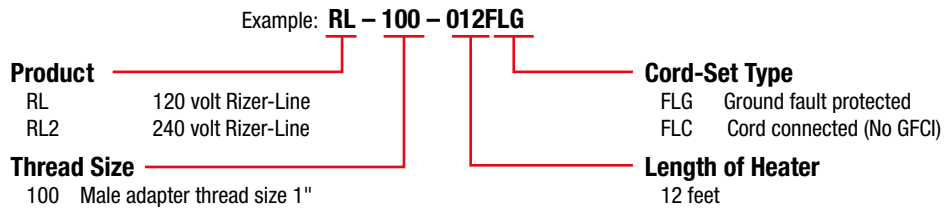

Rizer-Line | Accessories

Product Code	Description
HLA-120	120V plug-in thermostat (GFC)
TIMER-120P	120V plug-in timer (GFC)
TIMER-240P	240V plug-in timer (GFC)
TIMER-CS	120/240V hard wire timer (CS)
MA-10	120/240V GFCI/ELCI (CS)
INSUL-1.00	Insulation sleeve for 1 inch ID pipe (1 5/8 inch ID, 6 ft long)
HLP-TAPE	Tape for insulation sleeve butt joints (100 ft)
INSUL-FOIL	Aluminum bubble foil insulation (16 in wide, sold by the foot)
INSUL-TAPE	All weather Aluminum foil tape (150 ft)
PLD-CG	Cable guards/protectors (pkg of 4, 6 in each)
WARRANTY	Extended 10 year limited warranty

Rizer-Line | Typical Cross Section

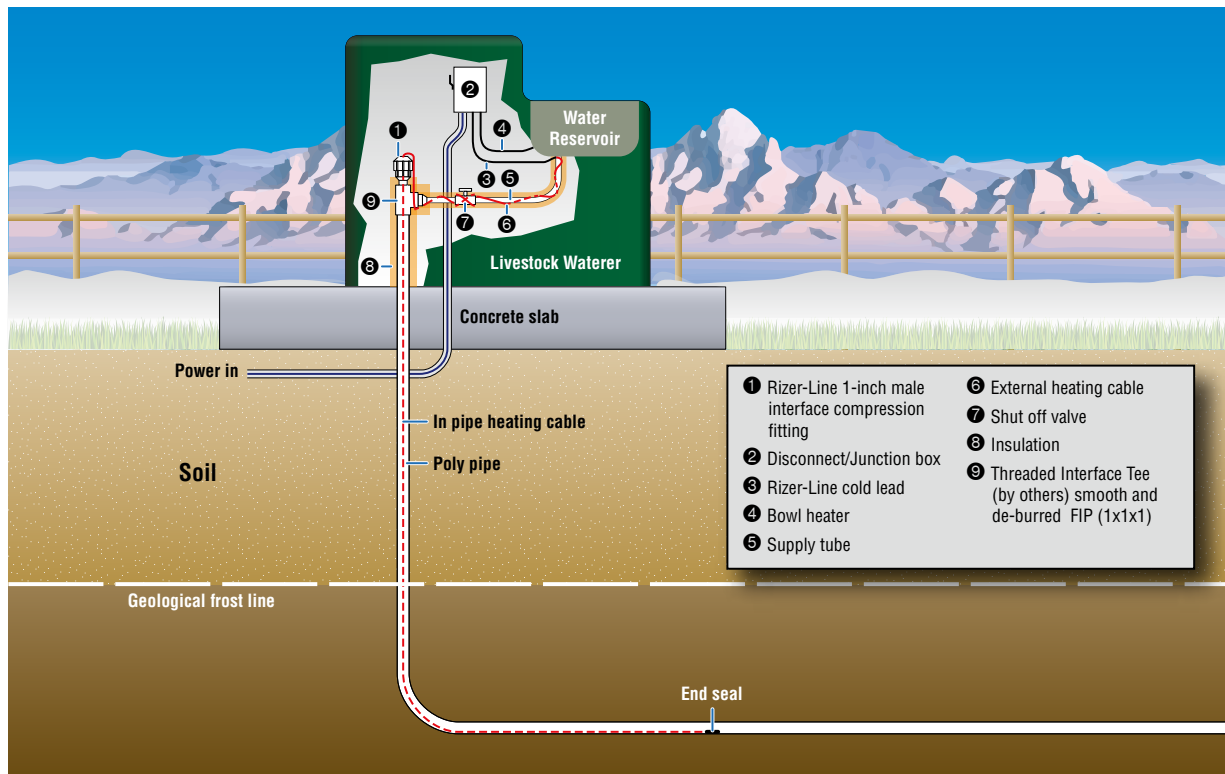

CARAPACE®

The Only Certified Rural and Municipal Freeze Protected Water Supply Pipe.

CARAPACE is a high performance, freeze protected (heated), HDPE polyethylene water pipe designed for use in municipal or domestic water supply and sewage force main applications.

Available as a complete job-ready system or on 1000 foot reels for field splicing and terminating.



heatline.com/carapace-factory-terminated
heatline.com/carapace-field-terminated



Patents USA and Canada NSF/ANSI 61

Features & Benefits

- The only certified rural and municipal freeze protected water supply pipe solution
- Unique construction provides superior heat transfer
- Approved for constant pressure systems
- Approved for direct earth burial and wet location
- Available factory finished, job-ready and tested prior to shipment
- Available cut-to-length for on-site field termination
- Available in a plug-in GFCI model or hard wire cord-set model depending on application
- Compatible with industry standard fittings
- Available in common lengths and long lengths
- Labour savings – no need to excavate below the frost line or blast rock
- Suitable for above ground applications with insulation
- Can be fully insulated to maximize energy efficiency
- Will never melt or overheat, even if pipe is dry
- Proven in -40°F weather above ground with 3/4 inch polyethylene insulation

Redundancy

- CARAPACE can be used as a back-up system
- When pipes are installed on the fringe of the frost line or in critical areas under roadways etc.,
- CARAPACE can be energized if freezing occurs, restoring water flow in minutes while preventing the need for costly jetting or steaming of pipes

For more Features and Benefits common amongst all Heat-Line brand systems refer to page 6.

Specifications

- cCSAus B137.1 approved (Canada and USA) LR85446
- cNSF 14-61 approved (Canada and USA)
- Approved for potable drinking water
- Certified Usage Type W Canada
- Installation Type A USA
- Self-Regulating/ conductive polymer heating cable
- Standard wattage 3 and 5 watts/foot at 50°F
- Available in 120V and 240V
- Max lengths 120V - 240 ft, 240V - 660 ft
- Available with either GFCI plug or CS hard wire connection
- 1 inch ID (SIDR-9) and 1.25 inch ID (SIDR-9) 200PSI NSF STD 14 polyethylene
- 1 inch CTS (SODR-9) 250PSI NSF STD 14 polyethylene
- Constructed of PE 4710 Resin HDPE
- Standard warranty of 5 yrs with optional 10 yrs

Applications

- Frozen sites where water is required
- Residential water supply, municipal water supply
- Sewage force mains
- Whenever deep blasting would be required to reach frost line
- Floating docks, sea walls, bridge crossings
- Construction sites, mining / oil / gas sites (ordinary locations)
- Shallow trenches
- Remote camps
- Ground source heat pump headers





Unique, Patented Product

CARAPACE is a unique, patented product constructed of high density polyethylene pipe (HDPE) with a proprietary self-regulating heating cable extruded directly onto the outer surface of the pipe. The heating cable is then mechanically protected by a high density polyethylene outer jacket or shell, ensuring the conductive core of the heating cable remains in continuous contact with the pipe wall while protecting it from mechanical injury.

The special construction of CARAPACE provides superior thermal heat transfer and unsurpassed energy efficiency when combined with thermal insulation and a thermostat.

CARAPACE is available in two options depending on job requirements. CARAPACE can be supplied factory finished to a specified length with power and end terminations installed or as a cut-to-length product for field measuring and terminating.

Alternative to Excavating

CARAPACE is an excellent alternative to costly excavating and blasting of rock or wherever permanent or temporary reliable freeze protection is required. The durability and termination flexibility of CARAPACE renders it a suitable product for a vast variety of applications, including residential, agriculture, commercial, industrial, mining and exploration, remote camps and construction.

Direct Earth Burial

CARAPACE is a CSA B137.1, NSF 14-61 approved product constructed with high density PE 4710 polyethylene for potability and is approved for direct earth burial and free air installations.

CARAPACE Rural Grade is available in 120 volt and 240 volt and sized in SIDR (internal diameter), 200 PSI rated, high density polyethylene. CARAPACE Rural Grade 250 PSI rated is also available by special order.

CARAPACE Municipal Grade is available in 240 volt and sized in CTS (copper tube size), 250 PSI rated, high density polyethylene. 120 volt Municipal Grade is available by special order.

Pipe temperatures can be maintained using insulation and thermostatic control.

Municipal and Domestic Freeze Protection

CARAPACE is a high performance product designed to provide energy efficient and reliable municipal and domestic pipe freeze protection.

Eliminates Steaming or Jetting Out Pipes

CARAPACE can be used continuously through winter as freeze protection or as a precautionary system in problematic geographies. In this case, as freeze-maintenance on the fringe of the frost line, the system can simply be energized in the event of a freeze. Water will begin flowing within a short time, preventing and eliminating the costly expense and need to steam or jet out pipes.

CARAPACE (Pre-Assembled and Factory Finished)

Example: **CR2 - 5 - 125 - 100 - GFC or CS**

Product	CR Rural, SIDR 200 psi, 120 volt	Cord-Set Type	GFC	CS (No GFC)	Note: "CS" systems must provide 20 Amp circuits for circuit lengths greater than 550 ft for 3 watt CARAPACE and 460 ft for 5 watt CARAPACE.
	CR2 Rural, SIDR 200 psi, 240 volt		Ground Fault Protected	Cord Connected	
	CM2 Municipal, CTS 250 psi, 240 volt, ONLY		<i>Max length</i>	<i>Max length</i>	
Wattage	5 5 Watt self-regulating heater		3 watt / 120 volt	270 ft	
	3 3 Watt self-regulating heater		5 watt / 120 volt	230 ft	
			3 watt / 240 volt	550 ft	
			5 watt / 240 volt	460 ft	
Pipe Size		Length of CARAPACE (ft)			
100	Pipe size 1" (CR – IPS-ID controlled) (CM – CTS)				
125	Pipe size 1 1/4" (CR – IPS-ID controlled)				

CARAPACE (Rural) (Sold in 1000 ft reels) *Internal diameter controlled*

Example: **RHPE2 - 5 - 100**

Product	RHPE SIDR 200 psi, 120 volt	Pipe Size	100	Pipe size 1" IPS-ID
	RHPE2 SIDR 200 psi, 240 volt		125	Pipe size 1 1/4" IPS-ID
Wattage	5 5 Watt self-regulating heater			
	3 3 Watt self-regulating heater			

Note: * IPS-ID pipe sizes only

CARAPACE (Municipal) (Sold in 1000 ft reels) *Copper Tube Size*

Example: **MHPE2 - 3 - 100**

Product	MHPE2 CTS, 250 psi, 240 volt	Pipe Size	100	Pipe size 1" CTS
Wattage	5 5 Watt self-regulating heater			
	3 3 Watt self-regulating heater			

Note: * CTS pipe sizes only.

Product Code	Description
GFA-STAT	120/240V hard wire thermostat with GFEP (CS)
TIMER-CS	120/240V hard wire timer (CS)
MA-10	120/240V GFCI/ELCI (CS)
INSUL-1.00	Insulation sleeve for 1 inch ID pipe (1 5/8 inch ID, 6 ft long)
INSUL-1.25	Insulation sleeve for 1 1/4 inch ID pipe (1 7/8 inch ID, 6 ft long)
INSUL-2.00	Insulation sleeve for 2 inch ID pipe (2 5/8 inch ID, 6 ft long)
HLP-TAPE	Tape for insulation sleeve butt joints (100 ft)
CR-CKIT	CARAPACE power and end seal kit
CR-CESS	CARAPACE end seal kit

Heat-Line[®]

Advanced Internal Water Supply Pipe System.

Heat-Line is a complete pipe system supplied with the Retro-Line heating cable system factory installed inside a 75 PSI, CSA approved polyethylene water pipe for new pipe installations.



Features & Benefits

- The only manufactured, self-regulating heating cable factory installed in pipe
- Available in 1 inch ID and 1 ¼ inch ID, 75 PSI polyethylene pipe
- Available in a plug-in GFCI model or hard wire cord-set model depending on application
- Customizable for various application requirements
- Length of heating cable can be adjusted (shortened) on the job-site by means of extracting the cable through plumbing fitting
- Available in common lengths and long lengths
- Heating cable is rigid enough to stay in place within the entire length of pipe
- Labour savings – no need to excavate below the frost line or blast rock
- Fully serviceable, can easily be removed if necessary
- Will never melt or overheat, even if pipe is dry
- Proven in -40°F weather above ground with 3/4 inch polyethylene insulation

For more Features and Benefits common amongst all Heat-Line brand systems refer to page 6.

Specifications

- cCSAus approved (Canada and USA) LR85446
- Approved for potable drinking water
- Certified Usage Type P Canada
- Installation Type A USA
- Self-Regulating/ conductive polymer heating cable
- Fluoropolymer outer jacket
- Standard wattage 3 watts/foot at 50°F, special wattage available
- Available in 120V and 240V
- Max lengths 120V - 230 ft, 240V – 300 ft
- Available with either GFCI plug or CS hard wire connection
- Engineered proprietary end seal technology
- Standard warranty of 5 yrs with optional 10 yrs

Applications

- New water supply lines requiring freeze protection
- Potable water supply 75 PSI or less
- Rural home and business water supply lines
- Lake homes and cottages/cabins
- Lake/river water source
- Wells
- Farms, agriculture





Complete Freeze Protected Polyethylene Pipe System

The Heat-Line system is supplied in a pre-determined length with the self-regulating heating cable already installed inside 75 PSI, CSA approved polyethylene pipe. Philmac plumbing fitting also supplied

Easy Installation

Just unroll the pipe and interface to plumbing fittings as necessary as you would with any non-heated poly.

Reliable Above Ground

Heat-Line has been proven to keep water from freezing in $-40^{\circ}\text{C}/\text{F}$ when installed above ground with 3/4 inch thick pipe insulation. No need to blast rock to bury the pipe.

Energy Efficient

Save up to 80% in energy consumption when combining thermostats and insulation. Thermostat and timers are optional with Heat-Line. They can be used to duty cycle the heating cable in an on/off operation making it more energy efficient. Heat-Line is safe to insulate and will make the heating cable operate more efficiently and reliably when used.

Requirements

Heat-Line orders require the length of system and size of pipe. Maximum system length in 240 volt is 300 feet.

Emergency Systems

In many applications Heat-Line is ordered for new builds where the water system is not yet complete. Heat-Line is ordered with insulation and installed on the ground until the following year where the trench can be dug and the same Heat-Line system buried.

Energy Efficient

With its self-regulating heating cable. Heat-Line has the ability to be the most energy efficient heating cable available proving you insulate and add a thermostat.

Fully Serviceable

The Heat-Line system is a fully serviceable product. Should you need to remove the heating cable, simply remove the plumbing tee fitting and pull out the heating cable.

Customizable

In many cases custom lengths can be ordered such as 80 feet of heating cable installed inside 100 feet of pipe.

Heat-Line | Product Code

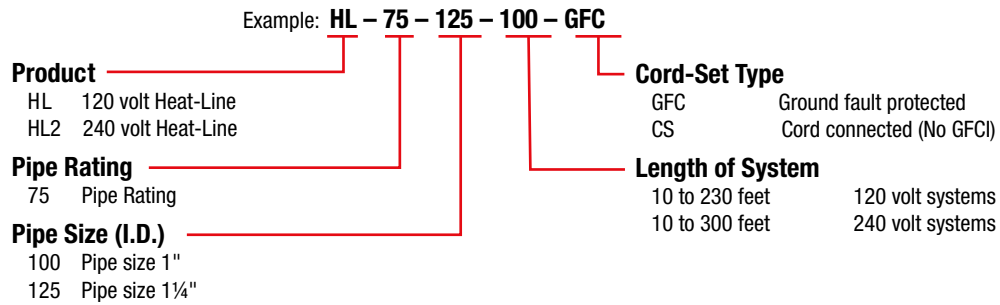

Heat-Line | Accessories

Product Code	Description
HLA-120	120V plug-in thermostat (GFC)
GFA-STAT	120/240V hard wire thermostat with GFEP (CS)
TIMER-120P	120V plug-in timer (GFC)
TIMER-240P	240V plug-in timer (GFC)
TIMER-CS	120/240V hard wire timer (CS)
MA-10	120/240V GFCI/ELCI (CS)
INSUL-1.00	Insulation sleeve for 1 inch ID pipe (1 5/8 inch ID, 6 ft long)
INSUL-1.25	Insulation sleeve for 1 1/4 inch ID pipe (1 7/8 inch ID, 6 ft long)
HLP-TAPE	Tape for insulation sleeve butt joints (100 ft)
WARRANTY	Extended 10 year limited warranty

Heat-Line | Typical Cross Section

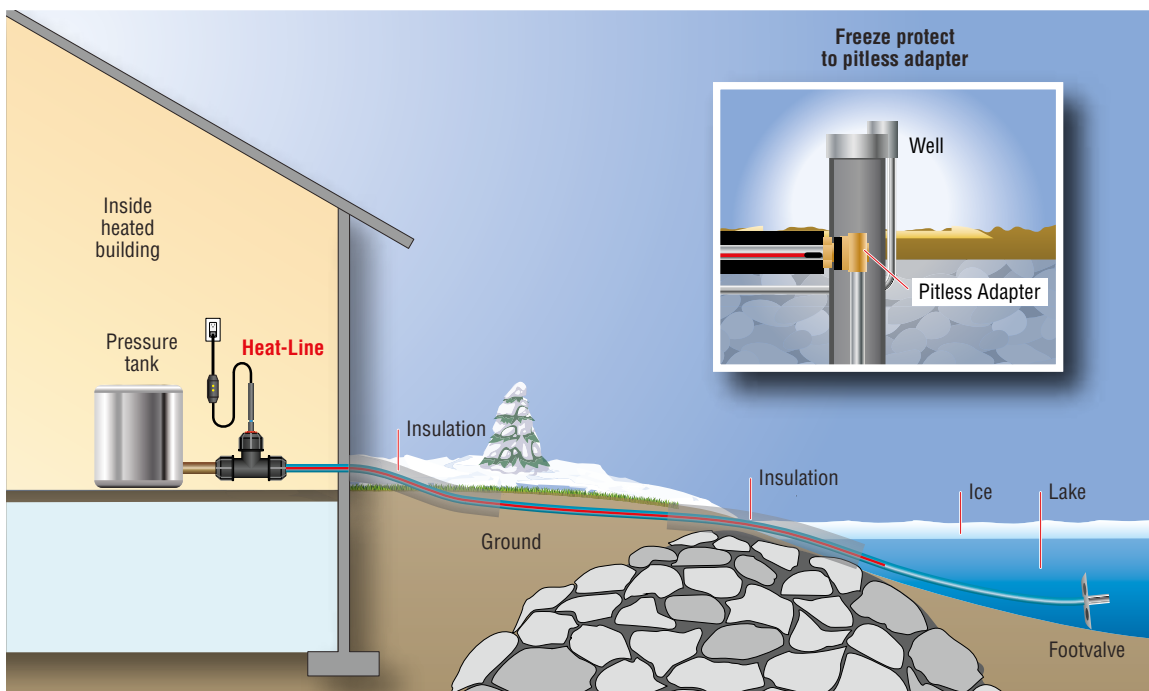

Paladin[®]/EXT

Multi-Use Freeze Protection for Pipes, Tanks and Vessels of All Types and Sizes.

Paladin/EXT Series is a job-ready freeze protection kit for use on both metal and plastic pipes. Paladin is acceptable for direct earth burial and wet location, making it suitable to be installed inside non-pressurized, non-potable pipes such as drainage pipes.



heatline.com/paladin-for-pipe
heatline.com/ext5-series
heatline.com/ext3t-series



Features & Benefits

- Suitable for direct earth burial and wet location
- Factory finished to length making installation simple, fast and cost effective
- Available in a plug-in GFCI model or hard wire cord-set model depending on application
- Customizable for various application requirements
- Available in common lengths and long lengths
- Suitable for multiple pipe sizes both metal and plastic
- Lengths 40 feet and greater are supplied on a dispensing reel for ease of installation (EXT's)
- Will never melt or overheat, even if pipe is dry
- Can be overlapped without concern of overheating
- Can be used to protect, pipes, tanks, vessels, soil heating and more
- Can be installed inside non-pressurized drain pipes
- Approved for applications with aggressive fluids or materials (EXT-T)
- Single trace installation is suitable for most applications saving product length

For more Features and Benefits common amongst all Heat-Line brand systems refer to page 6.

- cCSAus approved (Canada and USA) LR85446
- Certified Usage W and S (Paladin only) Canada
- Installation Type A USA
- Approved for direct burial and wet location
- Self-Regulating/ conductive polymer heating cable
- Thermo Plastic Elastomer (TPE) jacket (Paladin and EXT-R)
- Fluoropolymer outer jacket (EXT-T)
- Standard wattage 5 watts/foot at 50°F (Paladin and EXT-R)
- Standard wattage 3 watts/foot at 50°F (EXT-T)
- Special wattages available
- Available in 120V and 240V
- Max lengths 120V - 230 ft, 240V - 550 ft
- Available with either GFCI plug or CS hard wire connection
- Standard warranty of 5 yrs with optional 10 yrs
- Suitable for exposure temperatures up to 150°F (65°C)

Applications

- Existing water supply lines subject to freezing
- Small diameter water supply lines
- Large diameter pipes
- Sewage pipes, drains and culverts
- All metal pipes, all plastic pipes
- Metal tanks, Non-metal tanks
- Lake homes and cottages, farms, agriculture
- Commercial, industrial, construction sites
- Camps, mining
- Soil heating
- Food processing plants (EXT-T)
- Parking garages

Specifications





Paladin vs EXT-R vs EXT-T

There is no mechanical and or physical difference between the Paladin and EXT-R series product groups. The Paladin system though however carries an additional certification designation which makes the Paladin certified for use in Roof and Gutter applications. These designations restrict the maximum product length allowed so to allow for longer pipe heat tracing systems we drop the Roof and Gutter designations and use the EXT-R product name.

The EXT-T heating cable is constructed with a fluoropolymer outer jacket resistant to aggressive fluids and or materials, such as animal urine, manure, gasolines and oils. The fluoropolymer jacket also has potability ratings so is suitable for certain food processing plant applications. In comparison the EXT-R and Paladin heating cables are constructed with an elastomeric outer jacket design for ordinary installations. Apart from the cable jacket material, another difference is the standard wattage available.

Practical and Versatile External Systems

Paladin/EXT is designed to be applied to the outside of the pipe, making it suitable for both small and large pipe diameters. Traditional style heat tapes must be pitched or spiraled around the pipes in order to apply an adequate amount of heat, making them very high in energy consumption. In most applications, the Paladin/EXT systems are installed in a single run, reducing the overall length of product by as much as 60 percent. For large pipe diameters or where more heat is required, a dual (double) trace system is adequate, which still saves on product length.

CSA Approved

Paladin/EXT carries CSA approvals for wet location and direct earth burial which is not found on any other external heating cable on the market.

The wet location approval allows the heating cable to be installed inside non-pressurized, non-potable, non-metallic or metallic pipes such as drains and culverts, making installation easy for pre-buried pipes. Direct earth burial allows installation on the outside of water supply lines and septic pipes before they are buried.

Versatile Applications

The Paladin/EXT systems are so versatile that they are used in a variety of applications, including but not limited to water supply lines such as lake/river to house, well to house, building to building, farm water or fluid supply, RV and marine water supply as well as under structure copper pipes, any exposed pipes, culverts, drains, tanks and even in some soil heating applications.

Safe on All Pipe Materials

Paladin/EXT is safe to use on all pipe materials, including plastic and metals, even if there is no water in the pipe. Insulation and a thermostat can be added to the system to further optimize energy efficiency.

Factory Finished

Paladin/EXT is factory finished to length making installation simple, fast and cost effective. The need for an electrician to provide on-site power and complex terminations is eliminated.

Paladin | Product Code

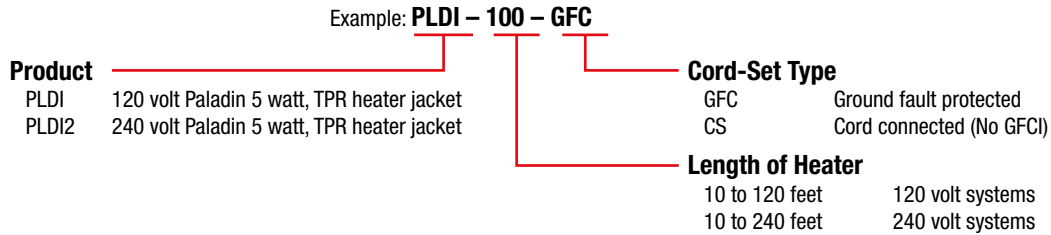

EXT Series | Product Code

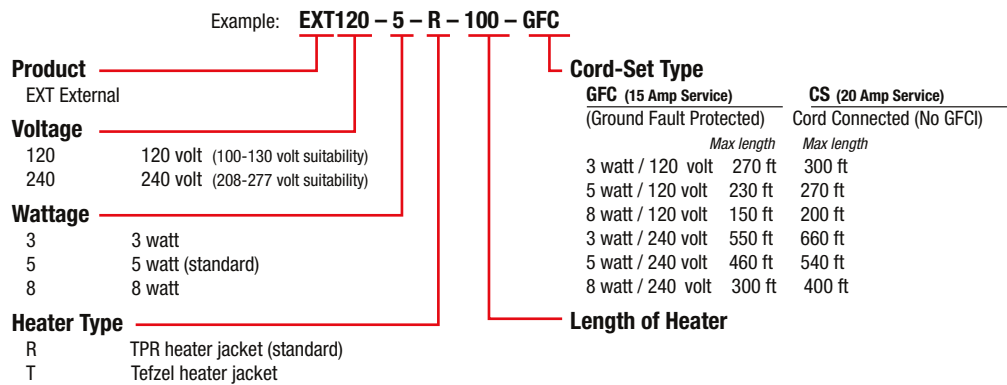

NOTE: Installers must provide 20 Amp circuits for CS circuit lengths greater than the maximum lengths set for GFC.

Paladin/EXT Series | Accessories

Product Code	Description
HLA-120	120V plug-in thermostat (GFC)
GFA-STAT	120/240V hard wire thermostat with GFEP (CS)
TIMER-120P	120V plug-in timer (GFC)
TIMER-240P	240V plug-in timer (GFC)
TIMER-CS	120/240V hard wire timer (CS)
MA-10	120/240V GFCI/ELCI (CS)
INSUL-1.00	Insulation sleeve for 1 inch ID pipe (1 5/8 inch ID, 6 ft long)
INSUL-1.25	Insulation sleeve for 1 1/4 inch ID pipe (1 7/8 inch ID, 6 ft long)
INSUL-2.00	Insulation sleeve for 2 inch ID pipe (2 5/8 inch ID, 6 ft long)
INSUL-3.00	Insulation sleeve for 3 inch ID pipe (3 1/2 inch ID, 6 ft long)
INSUL-4.00	Insulation sleeve for 4 inch ID pipe (4 1/2 inch ID, 6 ft long)
HLP-TAPE	Tape for insulation sleeve butt joints (100 ft)
INSUL-FOIL	Aluminum bubble foil insulation (16 in wide, sold by the foot)
INSUL-TAPE	All weather Aluminum foil tape (150 ft)
PLD-CG	Cable guards/protectors (pkg of 4, 6 in each)
WARRANTY	Extended 10 year limited warranty

Tandem-Link[®]

Wet Location Inter-Connecting Freeze Protection Systems.

Tandem-Link units are watertight job-ready heating cable systems that plug directly into one another, allowing on site length flexibility.



Features & Benefits

- The only inter-connecting heating cable product available
- Available in a plug-in GFCI model or plug-in no GFCI depending on application
- Can use up to 3 units to adjust length as required
- Can be used as permanent or temporary installation
- Watertight connection system allows rapid installation / removal / re-use
- Investment protection – segments are re-usable
- Simply disconnect, store and re-use
- Available in common lengths and long lengths
- Suitable for multiple pipe sizes both metal and plastic
- Will never melt or overheat, even if pipe is dry
- Can be overlapped without concern of overheating
- Can be used to protect, pipes, tanks, vessels and more
- Factory finished, job-ready – no liability for installer
- Installation is simple, fast and cost effective
- Single trace installation is suitable for most applications saving product length

For more Features and Benefits common amongst all Heat-Line brand systems refer to page 6.

Specifications

- cCSAus approved (Canada and USA) LR85446
- Certified Usage W Canada
- Installation Type A USA
- Certified for damp locations
- Self-Regulating/ conductive polymer heating cable
- Thermo Plastic Elastomer (TPE) jacket
- Standard wattage 5 watts/foot at 50°F
- Available in 120V and 240V
- Max lengths 120V - 205 ft, 240V - 410 ft
- Available with either GFCI plug or regular plug for field GFCI installation
- Wetguard male and female plug ends certified for wet location NEMA Type 4, 4X, 6, 6P
- Maximum 3 connected cables and/or maximum length per voltage
- Standard warranty of 5 yrs
- Suitable for exposure temperatures up to 150°F (65°C)

Applications

- Anywhere temporary water or non-flammable fluid pipes are exposed to freezing





Inter-Connecting Systems

Temporary wet location inter-connecting freeze protection systems.

Factory Finished, Job Ready

Tandem-Link systems are factory finished, job-ready heating cable systems that plug directly into one another, allowing on site length flexibility without the requirement of an electrician for field splicing and terminating in extreme climate conditions.

Self-Regulating

Tandem-Link systems are self-regulating, making them safe for use on all pipe materials, which may or may not always be filled with fluid. Insulation can always be added to increase efficiency and allow operation even in the harshest environments.

Wet Location Certified

Tandem-Link systems are supplied with quality, durable, wet location certified plug and receptacle connections.

Cold Weather Reliability

Tandem-Link systems are suitable for many applications, including cold weather construction requiring permanent or temporary water or fluid pipe heating. If used in a temporary application, the Tandem-Link system can be simply unplugged, rolled up and stored until it is required again for the next project.

CSA Approved

CSA approved for wet location.

Maximum 3 connected cables and

- 120 volt maximum connected length 205 feet
- 240 volt maximum connected length 410 feet

Practical Installation

Tandem-Link is designed to be applied to the outside of the pipe, making it suitable for both small and large pipe diameters. Traditional style heat tapes must be pitched or spiraled around the pipes in order to apply an adequate amount of heat, making them very high in energy consumption.

In most applications, the Tandem-Link systems are installed in a single run, reducing the overall length of product by as much as 60 percent. For large pipe diameters or where more heat is required, a dual (double) trace system is adequate, which still saves on product length.

Safe on All Pipe Materials

Tandem-Link is safe to use on all pipe materials, including plastic and metals, even if there is no water in the pipe. Insulation and a thermostat can be added to the system to further optimize energy efficiency.

Tandem-Link Product Code

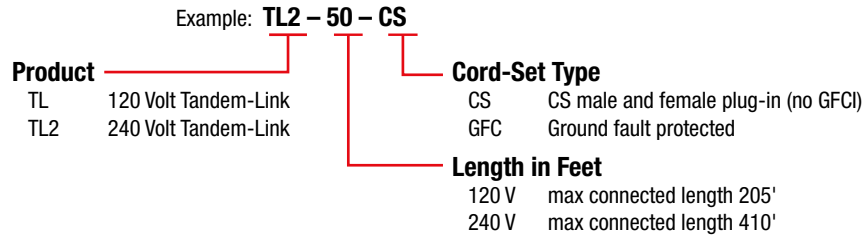

Tandem-Link | Accessories

Product Code	Description
HLA-120	120V plug-in thermostat (GFC)
GFA-STAT	120/240V hard wire thermostat with GFEP (CS)
TIMER-120P	120V plug-in timer (GFC)
TIMER-240P	240V plug-in timer (GFC)
TIMER-CS	120/240V hard wire timer (CS)
MA-10	120/240V GFCI/ELCI (CS)
INSUL-1.00	Insulation sleeve for 1 inch ID pipe (1 5/8 inch ID, 6 ft long)
INSUL-1.25	Insulation sleeve for 1 1/4 inch ID pipe (1 7/8 inch ID, 6 ft long)
INSUL-2.00	Insulation sleeve for 2 inch ID pipe (2 5/8 inch ID, 6 ft long)
INSUL-3.00	Insulation sleeve for 3 inch ID pipe (3 1/2 inch ID, 6 ft long)
INSUL-4.00	Insulation sleeve for 4 inch ID pipe (4 1/2 inch ID, 6 ft long)
HLP-TAPE	Tape for insulation sleeve butt joints (100 ft)
INSUL-FOIL	Aluminum bubble foil insulation (16 in wide, sold by the foot)
INSUL-TAPE	All weather Aluminum foil tape (150 ft)
PLD-CG	Cable guards/protectors (pkg of 4, 6 in each)

Tandem-Link | Typical (120 Volt) Application

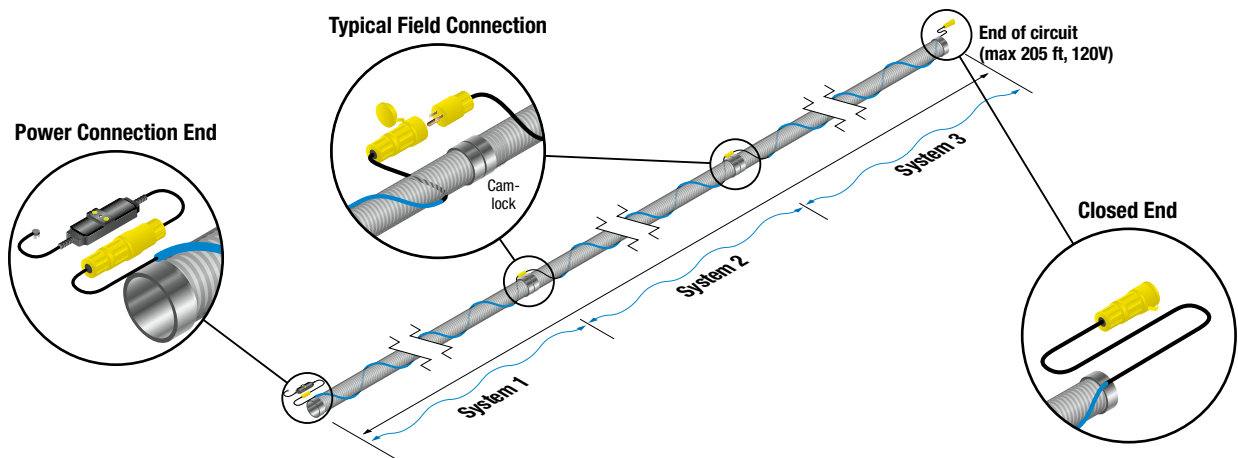

Kompensator®

Low Voltage Custom Manufactured Pipe Freeze Protection made to Suit Various Applications.

Kompensator systems are low voltage heating cables which are used in freeze protection applications for both metallic and non-metallic pipes, tubes, and hoses. These high quality heating cables are designed to be used in a variety of freeze protection applications including the transportation industry and are compatible with off-grid (solar and wind) and battery/alternator systems.



Features & Benefits

- The only job-ready low voltage heating cable system available
- Factory finished, job-ready – minimized liability for installer
- Each finished system is tested prior to shipment
- Manufactured to finished lengths for individual service requirements
- Customizable for various application requirements
- Compatible with DC and AC voltages
- Compatible with off-grid (solar and wind) and alternator battery generators
- Compatible with various methods of power generation including battery alternators
- Can be directly connected to alternator systems without need of inverters
- Continuous ground path
- Suitable for multiple pipe sizes both metal and plastic
- Can be fully insulated to maximize energy efficiency
- Thermostat is an available option
- Will never melt or overheat, even if pipe is dry
- Can be used to protect, pipes, hoses and more
- Suitable for direct burial and wet location
- Can be overlapped without concern of overheating
- Intended for ordinary locations only

For more Features and Benefits common amongst all Heat-Line brand systems refer to page 6.

Specifications

- Low voltage heating cable
- Self-Regulating/ conductive polymer heating cable
- Thermo Plastic Elastomer (TPE) jacket
- Standard wattage 3, 5 watts/foot at 50°F
- Available in 12V and 24V
- Max lengths 12V - 40 ft, 24V - 60 ft
- Supplied with 6 ft supply cord for direct hard wire connection
- Standard warranty of 1 yr
- Suitable for exposure temperatures up to 150°F (65°C)

Applications

- Transportation industry including fire and fluid delivery trucks
- Hydraulic and condensate fluid lines
- Existing water supply lines subject to freezing
- Small diameter water supply lines
- Large diameter pipes
- All metal and plastic pipes
- Rubber and PVC Hoses
- Metal tanks
- Non-metal tanks
- Farms, agriculture
- Commercial, industrial
- Camps
- Mining





Job Ready System

Kompensator systems are the only low voltage, factory finished, job-ready heating cable systems that are designed to provide safe, efficient and reliable freeze protection.

Applied to Outside of Pipe

Kompensator is designed to be applied to the outside of the pipe, making it suitable for both small and large pipe diameters. Traditional heat tapes must be pitched or spiraled around the pipes in order to apply an adequate amount of heat, making them very high in energy consumption.

Install in Single Run

In most applications, the Kompensator system is installed in a single run, reducing the overall length of product by as much as 60 percent. For large pipe diameters or where more heat is required, a dual (double) trace system is adequate, which still saves on product length.

Oil Lines, Pumps, Hoses

The Kompensator system is so versatile that it can be used in a variety of applications where 12 and or 24 volt power is available, including but not limited to, small diameter hoses, appliance and comfort heating, condensate freeze protection, oil lines, hydraulic hoses, pumps and compressed air systems.

Transportation Industry

When used in the recreational vehicle and transportation industry, Kompensator systems are capable of maintaining hydraulic oil and other fluid viscosities in cold temperatures, minimizing stress while maximizing winter performance.

Safe on Plastic and Metal

Kompensator is safe to use on all pipe and hose materials, including plastic and metals, even if there is no water in the pipe. Insulation and a thermostat can be added to the system to further optimize energy efficiency. Heat-Line offers a low voltage thermostat option which can be used to duty cycle and regulate the heating cable system within a specific temperature range.

Simple, Fast, Cost Effective

Kompensator is factory finished to length and provided with a complete set of installation instructions making installation simple, fast and cost effective.

Customizable

Kompensator is a common OEM product completely customized for specific applications. Even single orders can easily be customized without time delay.

Example: **KHL123 – 040 – CS**

Product

KHL123	12 volt 3 watt per foot
KHL125	12 volt 5 watt per foot
KHL243	24 volt 3 watt per foot
KHL245	24 volt 5 watt per foot

Cord-Set Type

CS Cord connected (No GFCI)

Length of Heater

5 to 40 feet	12 volt 3 watt per foot systems
5 to 30 feet	12 volt 5 watt per foot systems
5 to 60 feet	24 volt 3 watt per foot systems
5 to 48 feet	24 volt 5 watt per foot systems

Notes: It is the requirement of the installer to provide proper voltage regulation and over-current protection. It is also the recommendation of Heat-Line that since the power consumption of the product can never be zero to install a shut-off switch to prevent the draining of batteries or power supply.

Product Code	Description
KHL-STAT	12/24V thermostat
INSUL-PAD	Elastomeric flexible insulation (10 ft long, 6 inch wide, ½ inch thick)
INSUL-TAPE	All weather Aluminum foil tape (150 ft)
INSUL-FOIL	Aluminum bubble foil insulation (16 in wide, sold by the foot)
INSUL-1.00	Insulation sleeve for 1 inch ID pipe (1 5/8 inch ID, 6 ft long)
INSUL-1.25	Insulation sleeve for 1 1/4 inch ID pipe (1 7/8 inch ID, 6 ft long)
INSUL-2.00	Insulation sleeve for 2 inch ID pipe (2 5/8 inch ID, 6 ft long)
HLP-TAPE	Tape for insulation sleeve butt joints (100 ft)
PLD-CG	Cable guards/protectors (pkg of 4, 6 in each)

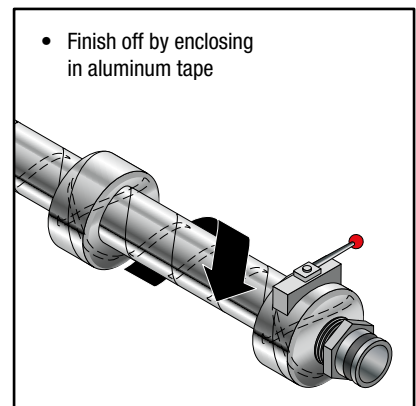
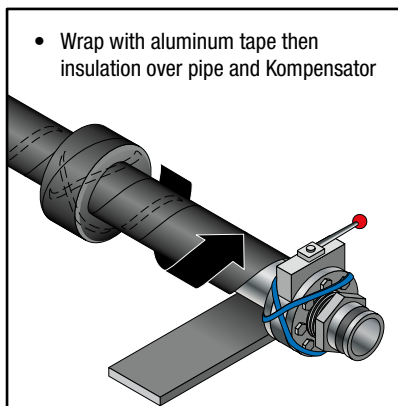
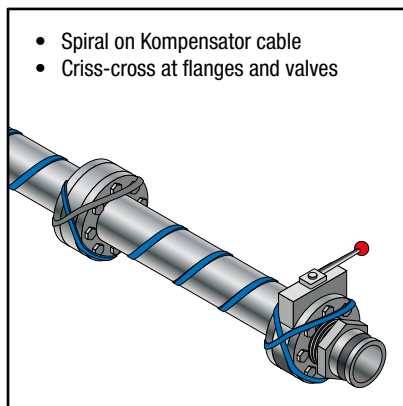

Paladin[®] for Roof

Award Winning Self-Regulating Heating Cable System Used for Many Roof and Gutter De-icing Applications.

Paladin is an exceptional freeze protection system for roof-de-icing and can be used on many different roof types and applications. Roof edge ice build-up, eave icing, icicles and ice dams can all be easily eliminated.



Features & Benefits

- The most reliable roof and gutter system available
- Available in a plug-in GFCI model or hard wire cord-set model depending on application
- Customizable for various application requirements
- Provides reliable roof and gutter freeze protection
- Compatible with a variety of roofing materials with various roofing materials including asphalt shingles, shakes, rubber, tar, wood, metal, and or plastic
- Can be used to effectively and efficiently heat trace around any skylight and or dormer windows
- Designed to be compatible with metal and plastic gutter and downspouts
- Easily and quickly installed on most roofs by means of roof clips or EDGE-CUTTER
- Will never melt or burn through plastic material, even if dry
- Can be used with a variety of control devices including snow controls, timers and thermostats

Specifications

- cSAus approved (Canada and USA) LR85446
- Certified Usage W and S Canada
- Installation Type A USA
- Self-Regulating/ conductive polymer heating cable
- Thermo Plastic Elastomer (TPE) jacket
- Standard wattage 5 watts/foot at 50°F
- Available in 120V and 240V
- Max lengths 120V - 120 ft, 240V - 240 ft
- Available with either GFCI plug or CS hard wire connection
- Standard warranty of 5 yrs with optional 10 yrs

Applications

- Suitable for asphalt shingles, aluminum, steel, and even slate
- Gutters, downspouts, drains
- Pitched roofs and flat roofs
- Residential roof applications
- Farms, agriculture
- Commercial, industrial
- Camps
- Mining





Multiple Design Options

When considering the Paladin for Roof system, Heat-Line can provide design ideas and important information regarding various application challenges. For standard gutter installations you install 1 foot of cable per foot of gutter and downspout. If the downspout is in the middle of the run, loop the Paladin down and back up, there is no concern of the Paladin system overheating if it comes into contact with itself. Double the length of the downspout for determining the length of Paladin to install. For valleys, run the heating cable two thirds of the way up and down the valley.

Cottage, Home, Resort

Paladin can be used in a variety of applications including, cottages, homes, resorts and farms. Snow sensors, thermostats, timers or other approved devices can be added to the system for increased energy efficiency.

Accessories

Heat-Line offers multiple accessories to compliment your Paladin heating cable such as roof clips, cable guards, downspout hanger brackets and of course Heat-Line's own EDGE-CUTTER roof de-icing system.

Control Devices

Heat-Line offers a variety of control devices to help your Paladin heat cable perform to its optimal, energy efficiency ability. Heat-Line offers timers, snow sensors, gutter ice sensors and more.

Quality, Reliability, Longevity

With Paladin you are getting the quality, reliability and longevity you would expect with a Heat-Line brand system. Not the nightmares you may expect with the common hardware store heat tapes.

Certification

Paladin is fully cSAUs certified for usage W and S (Canada), installation Type A (USA) for roof and gutter de-icing applications.

Conventional and Flat Roof De-Icing

Paladin is an exceptional freeze protection system designed for use on many different roof types and materials. It can be installed in a conventional serpentine configuration using roof clips or for a more aesthetically pleasing option it can also be combined with the Heat-Line EDGE-CUTTER channel flashings system. Either option will provide reliability and energy efficiency. Paladin is also suitable for flat roof applications as it will provide melt water paths towards the drains and even down the drain pipes.

Gutter, Downspout and Drain De-Icing

Paladin is fully certified to trace inside gutters, downspouts and remarkably even into the drain pipes themselves. Paladin carries the unique wet location approval due to Heat-Line's advanced boot end seal technology. This allows the heating cable to safely and reliability trace inside the drain pipes until the pipe exists the ground or natural frost protection is achieved.

Paladin for Roof | Product Code

Example: **PLDI – 100 – GFC**

Product		Cord-Set Type	
PLDI	120 volt Paladin 5 watt, TPR heater jacket	GFC	Ground fault protected
PLDI2	240 volt Paladin 5 watt, TPR heater jacket	CS	Cord connected (No GFCI)
		Length of Heater	
		10 to 120 feet	120 volt systems
		10 to 240 feet	240 volt systems

Paladin for Roof | Accessories

Product Code	Description
TIMER-120P	120V plug-in timer (GFC)
TIMER-240P	240V plug-in timer (GFC)
TIMER-CS	120/240V hard wire timer (CS)
MA-10	120/240V GFCI/ELCI (CS)
PLD-CG	Cable guards/protectors (pkg of 4, 6 in each)
PLD-RC	Roof clips (package of 10)
PLD-ECA	Angle EDGE-CUTTER flashing
PLD-ECF	Flat EDGE-CUTTER flashing
EC-MEM	EDGE-CUTTER membrane (metal roofs)
PCN-RDK-1	Downspout hanger kit
GIT-1	Gutter ice sensor (requires controller, PD-PRO or GF-PRO)
CIT-1	Snow sensor (requires controller, PD-PRO or GF-PRO)
SNOW-OWL	Aerial snow sensor (requires controller, PD-PRO or GF-PRO)
LCD-8	Configurable snow switch controller
PD-PRO	Snow/ice controller
GF-PRO	Snow/ice controller with GFEP
WARRANTY	Extended 10 year limited warranty

Paladin for Roof | Sample Application

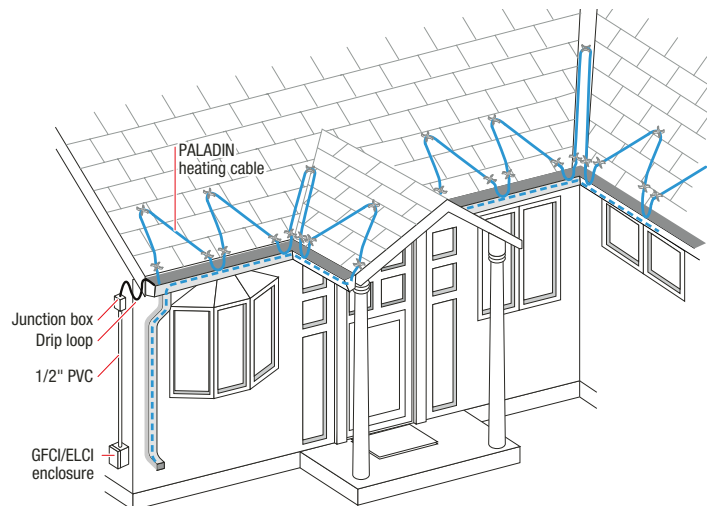

EDGE-CUTTER[®]

Aesthetically Pleasing Aluminum Channel Flashings Designed for Advance Roof De-icing Applications.

EDGE-CUTTER channels flashing are designed to prevent ice build-up, icicles, or ice dams on the leading roof edge and troublesome roof valley areas. EDGE-CUTTER is engineered to be used with a variety of different roofing materials such as asphalt shingles, aluminum, steel, and even slate.



Features & Benefits

- 4 foot feathered aluminum flashing complete with cap
- Flat and Angled flashing available to suit various application requirements
- Provides a mechanically protected channel for heating cable
- Vastly reduces total amount of heating cable required by as much as 75%
- Fast, easy installation
- Can be cut for customization on the job-site
- Can be used under all roofing materials including metal, asphalt and slate
- For new or existing roofs
- Aesthetically pleasing
- Many different uses
- Can be used with Paladin heating cable systems
- Can be used with Heat-Line cut-to-length heating cables
- Membrane available for metal roofs
- Thermostats and other control devices are optional
- Will not allow the heating cable to melt or overheat
- Energy efficient when compared with traditional roof de-icing systems
- Compatible with hydronic heated fluid melting systems
- Proven in extreme cold climates
- Fast installation with approved fasteners and/or appropriate adhesives

Specifications

- 4 feet of Aluminum EDGE-CUTTER flashing with cap
- 5 ½ inch width to be installed under roofing material
- Exposed cap width ¾ inch, can be painted to match roof covering
- Suitable for used with all Heat-Line self-regulating heating cables approved for roof
- Manufactured in North America
- 6 mil urethane membrane factory installed available upon request for steel roof applications

Applications

- Suitable for asphalt shingles, aluminum, steel, and even slate
- Residential roof applications
- Farms, agriculture
- Commercial, industrial
- Camps
- Mining



Aesthetically Pleasing De-Icing

EDGE-CUTTER feathered aluminum channel flashings are an aesthetically pleasing option to prevent ice build-up, icicles, or ice dams in roofing applications. When used in combination with Heat-Line, Paladin for Roof heating cable systems offers the most reliable, energy efficient roof de-icing system on the market.

Combine with Cut-to-Length Heat Cable

For commercial and or industrial applications, Heat-Line's Cut-to-Length heating cables offer an energy efficient and reliable solution when combined with Edge-Cutter. Each EDGE-CUTTER feathered aluminum channel flashing is 4 feet in length and has a channel to accommodate the self-regulating heating cable. The flashing is installed under the leading roof edge using screws, nails, or adhesives. The flashing will extend under the leading edge of roofing approximately 5 1/2 inches.

Simple Installation

Multiple lengths of the EDGE-CUTTER can be butted together, with room for expansion, to reach required linear length of protection. The Paladin system or Heat-Line Cut-to-Length self-regulating heating cable is then installed within the channel and a cap secures it in place. As the heating cable warms, energy is transferred through the feathered aluminum to melt the leading edge of ice or snow.

Angled or Flat Edge

The EDGE-CUTTER system is provided in two separate models. The angled EDGE-CUTTER model is commonly used for the leading edge of the roof as it provides a proper drip edge, while the flat EDGE-CUTTER model is designed to be used in many other areas of the roof including but not limited to edges and valleys.

Low-Pitched, Valley, Edge

The versatility of the EDGE-CUTTER product makes it a perfect solution for low-pitched roofs, valleys, roof edges, and drip edges.

Versatile Applications

EDGE-CUTTER is designed to suit a wide variety of applications and work in conjunction with a diverse number of roofing materials including but not limited to asphalt shingles, aluminum, steel and even slate. If a metal roof is present, the EDGE-CUTTER channel flashing should be ordered with a 6 mm urethane membrane factory installed directly onto the flashing to prevent galvanic oxidation between dissimilar metals.

Tailor on Site

Although the EDGE-CUTTER flashings are provided in 4 inch lengths they can easily be tailored on site to suit your specific application.

EDGE-CUTTER | Product Code



EDGE-CUTTER | Accessories

Product Code	Description
EC-MEM	Membrane EDGE-CUTTER (metal roofs)
PLDI	Paladin heating cable system to specific length
CUT-TO-LENGTH	Cut-to-Length heating cable

EDGE-CUTTER | Sample Application

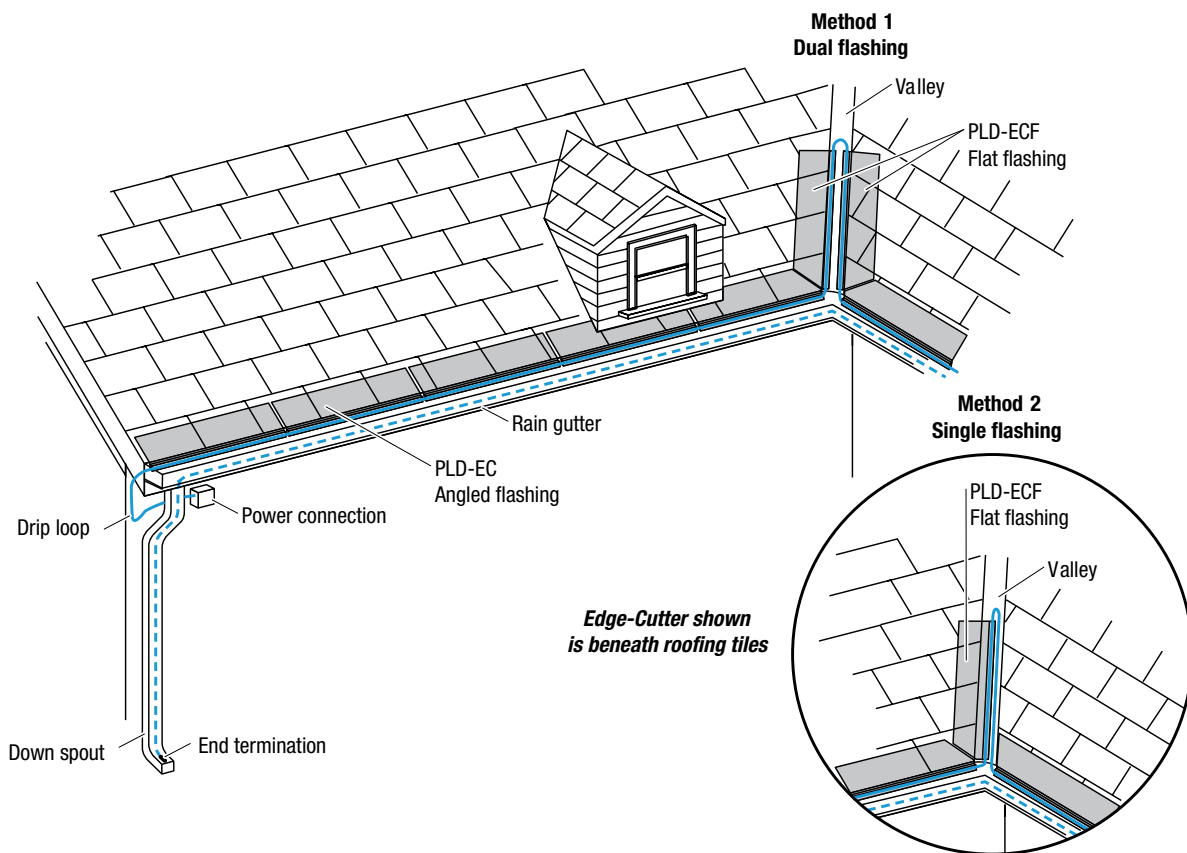

ArcticVent®

The World's Only Freeze Protected Plumbing Vent Stack.

ArcticVent is a certified commercial and residential freeze protected plumbing vent, proven throughout the circumpolar regions of the world and replaces many diameters and sizes of unprotected vents.



Features & Benefits

- The only freeze protected plumbing vent stack available
- Available in hydronic or plug-in GFCI model or hard wire cord-set model depending on application
- Provides reliable plumbing vent freeze protection
- Suitable for all types of roofs (roof flashing not included)
- Up to 6 units per 15 amp dedicated 120 volt circuit
- No need to oversize stack diameters
- Can be adapted to existing PVC, ABS or other vent pipes
- Can be installed on many vent diameters with the use of a transition coupler
- Constructed out of LEXAN® for high strength in severe cold
- Longitudinal tether to prevent falling ice within stack
- Control devices such as timers and thermostats optional
- Proven results throughout circumpolar regions

Specifications

- cCSAus approved (Canada and USA) LR85446
- Enclosure Type 3R
- Available in electric and hydronic models
- 3-inch slip-fit coupling (2 part transition epoxy included)
- 3-inch (internal diameter) freeze protected LEXAN® enclosure
- 5-inch outside diameter
- Self-Regulating/ conductive polymer heating cable
- 120 volt or 240 volt, total 75 watts at 50° F
- Available with either GFCI plug or CS hard wire connection
- Standard warranty of 5 yrs with optional 10 yrs

Applications

- New and retrofit installation
- Residential
- Cabins, cottages
- Construction trailers
- Commercial, residential and industrial buildings
- Cold weather construction camps





cCSAus Approved

ArcticVent is the only cCSAus approved solution to freeze protect plumbing vent stacks and provide healthier living conditions in extremely cold climates.

Prolonged cold temperatures cause plumbing vent stacks to ice up and form a blockage as humid air rises, condenses and freezes. The result is pungent, unhealthy air backing up inside the dwelling which can be dangerous to the inhabitants.

Easily Installed

ArcticVent can be easily installed in new applications as the vent interfaces to standard pipes with the use of two part epoxy (included). ArcticVent can also be retro-fitted to existing 3 inch ABS or PVC pipe or adapted to fit other vent diameters. With ArcticVent, there is no longer a need to install unheated oversized diameter plumbing vents.

Continuous or on Demand

ArcticVent is constructed with LEXAN® for high strength in severe cold. While it is recommended to operate ArcticVent under continuous power in the colder months for freeze maintenance, it can be powered when required to thaw a frozen plumbing stack. The ArcticVent is constructed with a center longitudinal tether to ensure any ice formations within the vent stack melt fully and do not dislodge prior.

Hydronic or Electric

ArcticVent is available in both hydronic and electric models depending on application requirements.

Electric models employ the unique and advanced performance of self-regulating heating cable technology which can effectively increase heat and energy output to sections along its length which are cold and simultaneously reduce heat and energy output to sections which are warm. Available in 120 volt or 240 volt, 75 watts total at 50° F.

Specifications

Each ArcticVent measures 3 feet long with a 3 inch ID and 5 inch OD.

Electric models available in 120 volt or 240 volt, GFCI or CS versions.

Hydronic models come with brass male thread for connection interface.

Proven

ArcticVent is proven effective in the most severe cold climates. Hundreds of units are installed in the most northern communities in Canada without fail for years. ArcticVent is constructed with LEXAN® for high strength in severe cold. While it is recommended to operate ArcticVent under continuous power in the colder months for freeze maintenance, it can be powered when required to thaw a frozen plumbing stack. The ArcticVent is constructed with a center longitudinal tether to ensure any ice formations within the vent stack melt fully and do not dislodge prior.

Energy Efficiency

To further increase the energy efficiency of your ArcticVent unit a thermostat, timer and or other control devices can be added to the system. The ArcticVent unit is already internally insulated to reduce heat loss and increase energy efficiency. The addition of a thermostat would allow you to duty cycle your ArcticVent system based on ambient air temperature, while a timer would duty cycle the ArcticVent on and off based on desired preset

Electric ArticVent

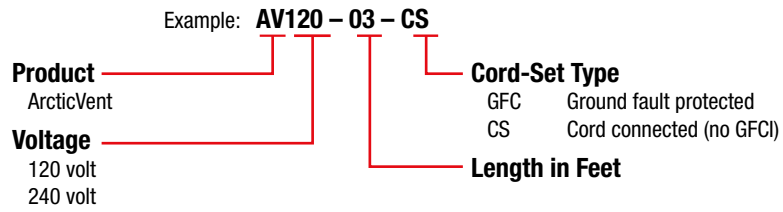

Hydronic ArticVent

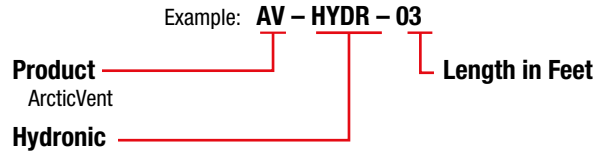

Product Code	Description
TIMER-120P	120V plug-in timer (GFC)
TIMER-240P	240V plug-in timer (GFC)
TIMER-CS	120/240V hard wire timer (CS)
MA-10	120/240V GFCI/ELCI (CS)
AS-FLASH	ArcticVent roof flashing for asphalt
ST-FLASH	ArcticVent roof flashing for steel
WARRANTY	Extended 10 year limited warranty

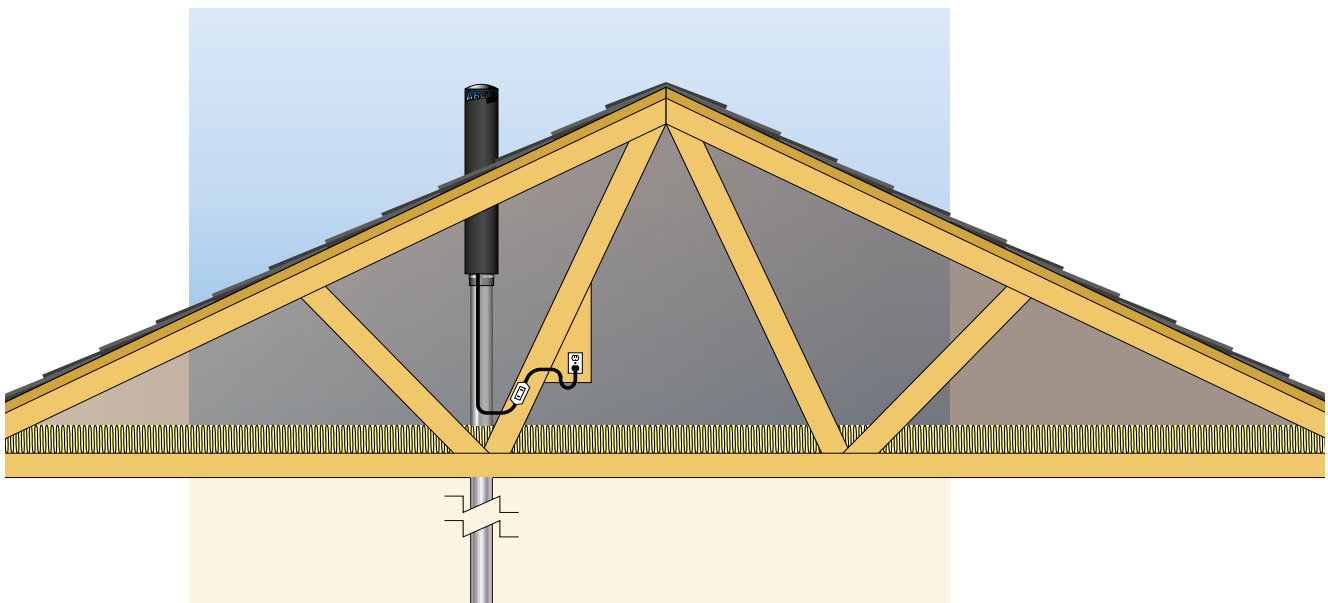

Cut-to-Length

Heating Cable

Industrial and Commercial Self-Regulating Heating Cable.

Cut-to-Length Heating Cables are top quality commercial, industrial self-regulating heating cables and power connection kits for ordinary and hazardous locations, roof and gutter de-icing.



General Heater Specifications

Buss Wire	14-16 AWG copper or nicked copper
Conductive core	Self-regulating / conductive polymer
Inner jacket	Polyolefin
Metallic overshield / Braid	Copper, tinned copper or stainless steel
Outer jacket	Polyolefin, fluoropolymer, TPR, TPE
Watts per foot / meter	3, 5, 8, 10, 15, 20/foot or 10-60/meter
Voltage	120, 208-277
Approvals	CSA, FM, UL
Environmental use(s)	Ordinary areas, Div. 2 hazardous locations, Corrosive environments, Roof and gutter
Reel length	Up to 1000 feet
Water resistant jacket	Yes
Flame retardant jacket	Yes
Can be overlapped	Yes
Applications	<ul style="list-style-type: none"> • Freeze protection of pipes • Fire protection system piping • Chilled water and plumbing pipes • Sump pump discharge pipes • Exposed P-traps • Cooling towers • Vessel freeze protection • Fluid flow and viscosity maintenance • Process temperature maintenance • Roof and gutter

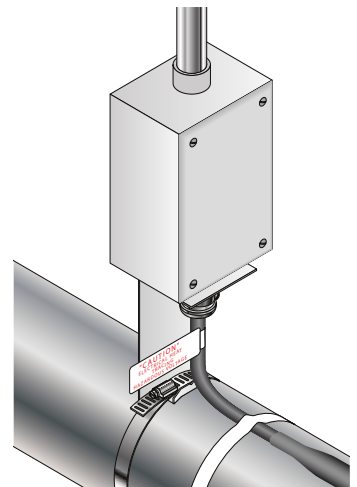
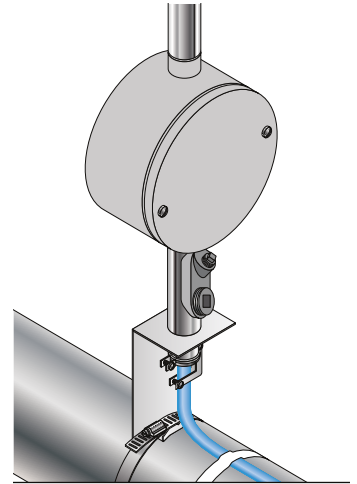

Self-Regulating Heating Cable

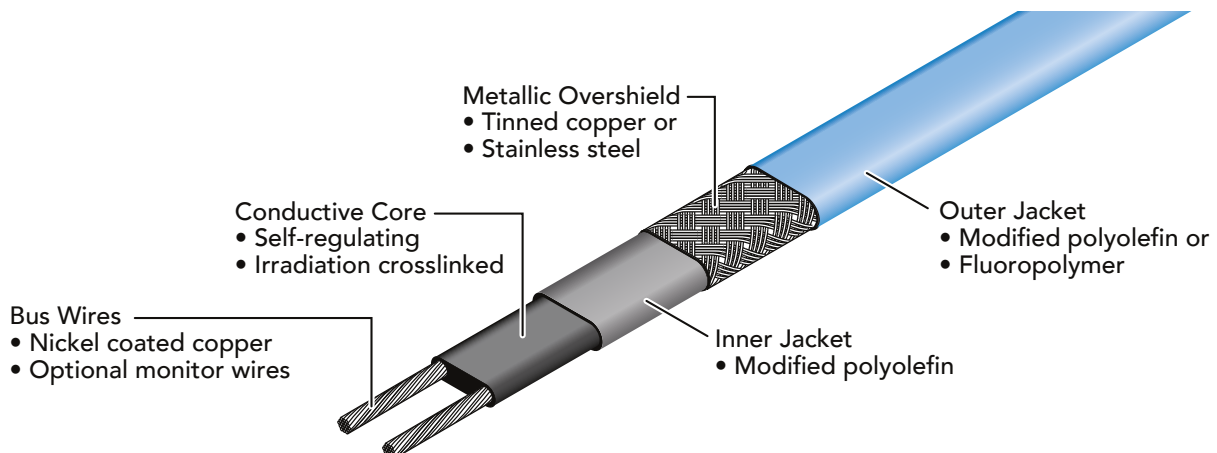



Heating Cable Options

Heat-Line provides excellent Cut-to-Length heat cables in a large or small order requirements at very competitive prices. These cables can maintain temperatures up to 150°F (65°C) and survive intermittent exposure up to 185°F (85°C) with power applied. They are designed for all types of heat tracing including pipe tracing, roof and gutter de-icing, vessel tracing and many more. All heating cables are North American made by the top manufacturers providing you a reliable solution.

Cost Savings

Many manufacturers specify their specific cables in various building plans, and Heat-Line's vast resource of products will almost always meet the building specification, providing equivalent performance with huge cost savings to the contractor. Heat-Line provides excellent Cut-to-Length heating cables in large or small order requirements at very competitive prices.

Industrial, Commercial

Heat-Line is a sole source, high volume provider of multiple types of industrial and commercial self-regulating heating cables, components and controls. Heat-Line carries major inventories with a full understanding of the products and can provide extremely competitive pricing.

Meets or Exceeds Most Building Specs

Heating cables are available in 120, 208, 240 and 277 volts, and wattages ranging from 3 to 20 watts per foot or 10 to 60 watts per meter. All heating cables meet or exceed most building specifications and carry regulatory approvals from CSA, FM and/or UL for ordinary and hazardous locations. Control options include: ambient and line sensing thermostats, snow melt sensors, ground fault protected thermostats and more.

Common Applications

Heat-Line Cut-to-Length freeze protection heating cables are ideal for keeping metallic and non-metallic pipes from freezing. These heat cables provide safe, reliable heat tracing for freeze protection of pipes, valves, tanks and similar applications. In commercial construction applications, these heaters can be used on a variety of applications such as; cooling towers, chilled water and plumbing pipes, sump discharge pipes, fire protection system piping and exposed P-traps. For industrial applications, their usage can include; water treatment facilities, vessel freeze protection and safety lines. Cut-to-Length heating cables are also ideal for process temperature maintenance, pipe freeze protection, fluid flow and viscosity maintenance. Medium and high temperature industrial and commercial grade self-regulating heating cables are also available.

Self-Regulating Technology

All Heat-Line Cut-to-Length heating cables offer the unique and advanced performance of self-regulating heating cable technology. These heaters can effectively increase heat and energy output to sections along its length which are cold and simultaneously reduce heat and energy output to sections which are warm. Even in applications where pipes are intended to be dry for short or extended periods of time, the heating cable will never over-heat or melt the pipe. These high quality heaters give you the peace of mind of reliable freeze protection without the risk. It has become an essential product for electricians, engineers and building officials overseeing commercial, industrial and municipal projects to provide safe and reliable pipe freeze protection.

Heating Cable Ordering Chart

for 2700 Series Self Regulating Heating Cable

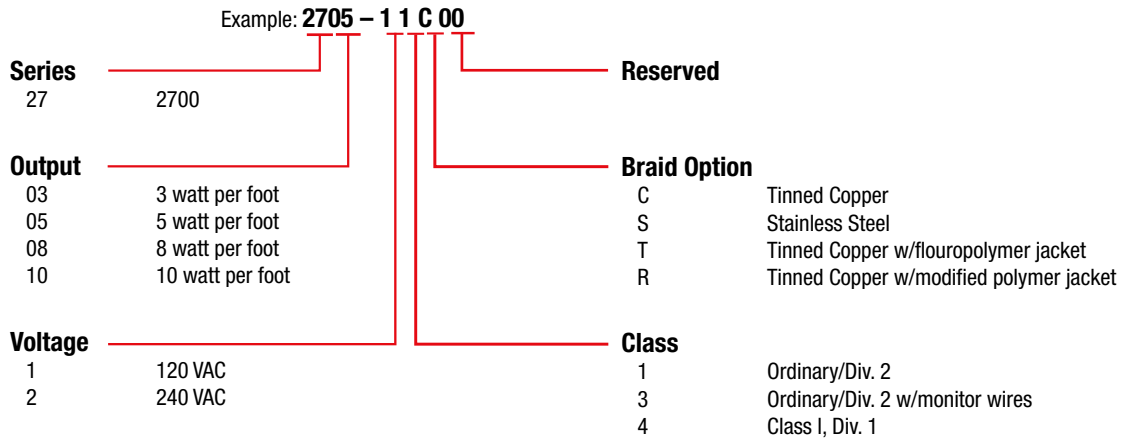

Standard Cut-to-Length Heating Cable | Part Numbers

2703-11R		3 watt/ft, 120V, TPE jacket, Self Regulating
2703-21R		3 watt/ft, 240V, TPE jacket, Self Regulating
2705-11R		5 watt/ft, 120V, TPE jacket, Self Regulating
2705-21R		5 watt/ft, 240V, TPE jacket, Self Regulating
2708-11R		8 watt/ft, 120V, TPE jacket, Self Regulating
2708-21R		8 watt/ft, 240V, TPE jacket, Self Regulating
2710-11R		10 watt/ft, 120V, TPE jacket, Self Regulating
2710-21R		10 watt/ft, 240V, TPE jacket, Self Regulating

Electrical Connection Kits | Part Numbers

1548-40000		Power and End Seal Connection Kit, FM Hazardous and Non-Hazardous
1548-4000C		Power and End Seal Connection Kit, CSA Non-Hazardous
1548-4010C		Power and End Seal Connection Kit, CSA Hazardous and Non-Hazardous
1548-40PTJ		Power Connection Kit, FM Hazardous and Non-Hazardous
1548-40RGP		Power and End Seal Kit, Roof and Gutter, CSA, UL
SRHC-ES		End Seal Kit, CSA/FM Hazardous and Non-Hazardous

For specific approval information on the above connection kits contact Heat-Line

Note: Other heating cables and electrical connection kits available by special request.

Thermostats & Timers

Complete Range of Control Devices to Increase heating Cable Efficiency.

Thermostats and or timers are a beneficial optional accessory when incorporated with any Heat-Line freeze protection system. Regardless of the overall system length and or operating voltage, a Heat-Line thermostat or timer will reduce energy costs by decreasing overall energy consumption.

A thermostat can be added to Heat-Line systems in order to duty cycle the heating cable at a specified temperature, where as a timer can be added to duty cycle the heating cable at specific timed intervals.



Thermostat/Timers

HLA-120



- ETL c-us Approved
- Easy to Read Front Panel Display
- 1 Year Limited Warranty
- Electronic, Plugs into normal 120 Volt 15 Amp Outlet
- 6.7m (22ft.) Temperature Sensor Lead
- Wide Temperature Differential Adjustment
- F/C Temperature Display
- Programmable, 5/2 Day Programming (Weekdays and Weekends can be different)
- Adjustable Set-Point, Minimum Temperature Setting 7°C (45°F)

GFA-STAT



- cULus Listed and Certified
- 2 Year Original Manufacturers Limited Warranty
- Nonhazardous Locations NEMA 4X Enclosure
- Supply Voltage 120, 208, 240, 277 volts, Single Phase
- Maximum Ampacity 30 amps at 277 VAC
- Sensor Lead Length of 20 feet (6m)
- Hard-Wired Usage Only (Professional Tradesperson Install Recommended)
- Adjustable Temperature Set Points of 30F, 38F, 45F and or 50F (-1.1C, 3.3 C, 7.2C and or 10C)
- GFCI Integral to Unit, 30 mA Protection

KHL-STAT



- Water and Dust Resistance to IP67
- RoHS Compliant
- 5 Year Original Manufacturers Limited Warranty
- Supply Voltages 6 to 24 volts DC
- Load Control Up To 10 amps (higher load switching available by special order)
- Accurate Set-Points, On at 45°F (7°C) and Off at 50°F (10°C)
- Weatherproof Housing/ Construction

HL-TIMER-CS/120P/ 240P



- cCSAus Certified and Listed under Energy Management Equipment
- Supply voltage 120 or 240 volts, Single Phase, 60 Hz
- Resistive Rating: 20 Amps at 120/240VAC, 28 VDC
- Enclosure Type 3
- **CS model** timer designed for hard usage installation with Heat-Line CS model heating cable systems
- **120P model** timer for 120V applications only, provided with Female 5-15R and Male 5-15P plug end tails for use with Heat-Line GFC 120V model heating cable systems
- **240P model** timer for 240V applications only provided with Female 6-15R and Male 6-15P plug end tails for use with Heat-Line GFC 240V model heating cable systems
- Provides 8 field selectable cycles durations (30sec., 1min., 3mins., 5mins., 10mins., 30mins., 1hr. and 4hrs.)
- Provides 30 different precise percentage selection options for ON TIME

Note: Other thermostat and control options not listed above are available from Heat-Line. Please contact Heat-Line directly to discuss other thermostat options and control devices not listed.

Insulation

Complete range of pipe insulation types and sizes.

Heat-Line systems are self-regulating, allowing insulation to be added without the concern of the pipe overheating. A thermally insulated pipe requires much less heat to protect and is not as susceptible to freezing. Extreme or variable temperature changes are not a concern as the pipe insulation provides better thermal consistency and efficiency throughout the entire pipe length.

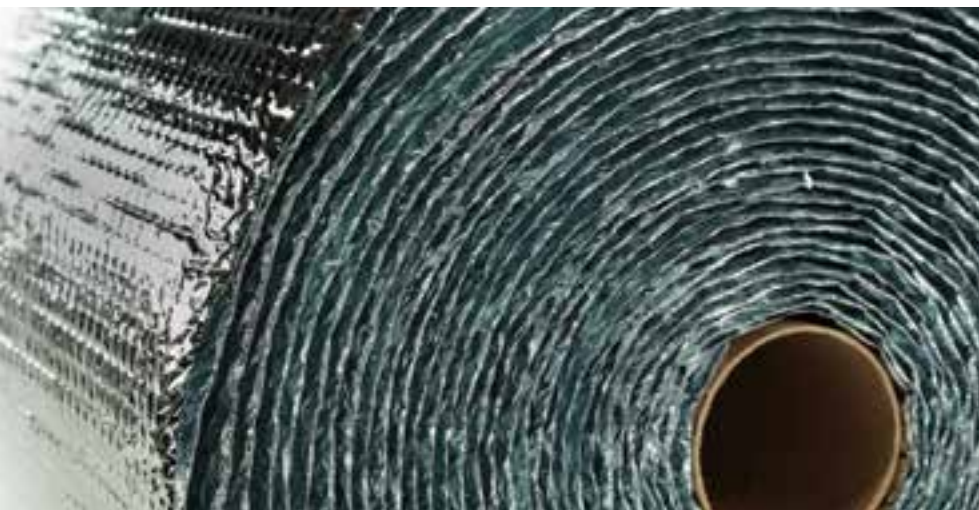

Minimize Heat Loss

While self-regulating technology is very efficient, it is important to understand there is always great heat loss from an uninsulated pipe, which causes the heating cable to produce high heat to compensate. When insulation is applied, heat is retained (heat loss minimized) within the pipe, allowing the heating cable to produce less heat to maintain the same temperature. For example, it would be foolish to install the most energy efficient furnace in your home and then fail to insulate your walls and ceilings. The furnace will only operate to its highest standard when used with insulation and a thermostat. The same idea applies with Heat-Line systems.

Do You Require Insulation?

Any section of Heat-Line freeze protected pipe remaining above ground is required to be thermally insulated. In all new applications insulation is recommended for energy efficiency. Note: For lake or river applications, insulation is only required to the water's edge (at low water mark). Water-proof, Styrofoam foam board type insulation can also be purchased from local building centers and is an excellent choice for direct earth burial applications.

Insulation | Part Codes

INSUL-1.00x6		Closed cell polyethylene insulation sleeve for 1" ID water pipes. Insulation is 1 5/8" ID, 3/4" wall, 6' in length.
INSUL-1.25x6		Closed cell polyethylene insulation sleeve for 1 1/4" ID water pipes. Insulation is 1 7/8" ID, 3/4" wall, 6' in length.
INSUL-2.00x6		Closed cell polyethylene insulation sleeve for 2" ID water pipes. Insulation is 2 5/8" ID, 3/4" wall, 6' in length.
INSUL-3.00x6		Closed cell polyethylene insulation sleeve for 3" ID water pipe. Insulation is 3 1/2" ID, 3/4" wall, 6' in length.
INSUL-4.00x6		Closed cell polyethylene insulation sleeve for 3" ID water pipe. Insulation is 4 1/2" ID, 1" wall, 6' in length.
INSUL-PAD		Elastomeric flexible closed-cell insulation, 1/2"(12.5mm) thick, 6" (152mm) wide, 10'(3m) long
INSUL-FOIL		16" wide aluminum reflective metalized foil bubble insulation, available by the foot or by each 125 ft (38m) roll

Insulation | Accessories

Product Code	Description
HLP-TAPE	Tape for insulation sleeve butt joints (100 ft)
INSUL-TAPE	All weather Aluminum foil tape (150ft)

Philmac[®] Fittings

Specialized Plumbing Compression Fittings.

Heat-Line is pleased to offer a wide range of Philmac 3G Compression style fittings designed for connection of polyethylene water pipes which includes SIDR IPS, OD IPS, and CTS normal dimension pipes. Philmac fittings are both NSF and CSA certified for potable water applications, both in above and below ground applications.



Proudly Recommended

Heat-Line is proud to recommend Philmac 3G Compression fittings as the premium choice for customers concerned with a long term performance and reliability. Heat-Line offers an extensive line-up of Philmac 3G plumbing fittings to meet the growing needs of the plumbing industry. The Heat-Line part numbers below represent the most commonly requested Philmac fittings, and therefore are readily available in inventory.

Special Orders Available

Heat-Line's extensive inventory of Philmac 3G fittings includes many other fittings of various sizes and pipe applications not listed below. Heat-Line can also special order to provide Philmac Fittings for applications beyond the current inventory.

Design

The Philmac 3G Compression series of fittings provide a compact, lightweight, and user friendly design that reduces the overall possibility of pipe twist while reaming completely serviceable.

Market Leaders

Philmac 3G Compression fittings are design to exceed required life expectancy ratings of 50 years

Philmac 3G SDR Compression Fittings | Part Codes

PC-100		Coupling for 1 inch ID Compression
PC-125		Coupling for 1 1/4 inch ID Compression
PMA-100		Male Adapter, 1 inch ID Compression x 1 inch MIP Thread
PMA-100/125		Male Adapter, 1 inch ID Compression x 1 1/4 inch MIP Thread
PMA-125		Male Adapter, 1 1/4 inch ID Compression x 1 1/4 inch MIP Thread
PMA-125/100		Female Adapter, 1 1/4 inch ID Compression x 1 inch FIP Thread
PFA-100		Female Adapter, 1 inch ID Compression x 1 inch FIP Thread
PFA-125		Female Adapter, 1 1/4 inch ID Compression x 1 1/4 inch FIP Thread
PBF-100		Female 90 Degree Elbow Adapter, 1 inch ID Compression x 1 inch FIP Thread
PBF-125		Female 90 Degree Elbow Adapter, 1 1/4 inch ID Compression x 1 1/4 inch FIP Thread

Philmac 3G CTS Compression Fittings | Part Codes

PC-100CTS		Coupling for 1 inch CTS Compression
PC-125CTS		Coupling for 1 1/4 inch CTS Compression
PMA-100CTS		Male Adapter, 1 inch CTS Compression x 1 inch MIP thread
PFA-100CTS		Female Adapter, 1 inch CTS Compression x 1 inch FIP thread

MilliAMP

A Certified, Stand-Alone 10 MilliAMP GFCI/ELCI Equipment Protection Device.

MilliAMP is an Equipment Leakage Circuit Interrupter (ELCI) designed for electrical equipment and shock protection of sewage pumps, water pumps, heating cables and many other electrical appliances.



MilliAMP

Development

MilliAMP was developed by Heat-Line to supply ground fault protection which is not specific to any particular electrical panels or equipment.

Specifications

The MilliAMP MA-10 is a safety and equipment protection device that can be sold with any 120 volt, 20 Amp or 240 volt, 16 Amp pump.

CAUTION

A MilliAMP device is primarily designed for equipment protection and while it does provide a high level of safety, it is not a Class A Ground Fault Circuit Interrupter (GFCI).

MilliAMP | Part Codes

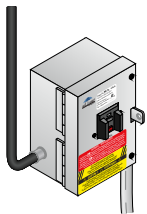

MA-10

| ELCI with enclosure, CSA approved, 10 mA typical trip level, 120 volt, 20 Amp or 240 volt, 16 Amp voltage rating

Sample Application

MilliAMP Wiring Through Pressure Switch and Starter to Submersible Pump.

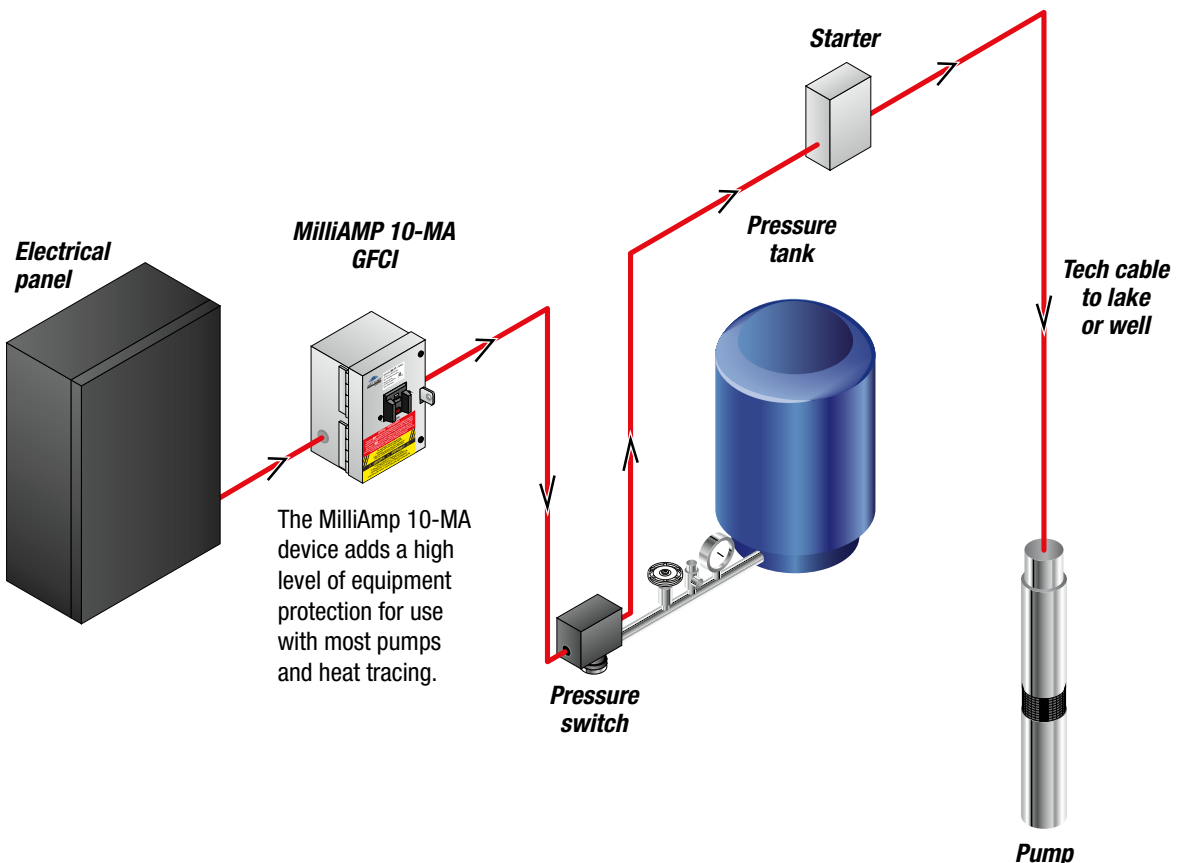

Surge-BLOK

A certified high performance surge suppression device for entire building.

Surge-Blok is an advanced surge protection device to protect your entire home or commercial establishment from transient, over-voltages and lightning.



Design

As modern homes rely on sensitive electronic controls, the need to protect against ongoing power variants has never been more important.

Heat-Line Surge-BLOK employs Strikesorb® technology from Raycap, non MOV, non sacrificial surge protection technology that will not fail. Surge protection for your entire home or commercial establishment from transients, over-voltages and lightning. Surge-BLOK protects every circuit from the electrical service. The most reliable surge protection technology now in a simple, easy to install platform.

Specifications

120-2S-S3-2-06-A-HL is suitable for use on a circuit capable of delivering not more than 200,000 rms symmetrical amperes, 150V maximum, when protected by a RK5 class fuse, or a circuit breaker rated at 50A or less (2 Port Connection).

120-2S-M3-3-06-A-HL Suitable for use on a circuit capable of delivering not more than 200,000 rms symmetrical amperes, 150V maximum, when protected by a 100A RK5 class fuse.

Operation

Normal operation is indicated by the illumination of the green LEDs. In the event of a fault or loss of power, the LEDs will turn off. The Form C relay contacts may be configured to notify a remote alarm system of a problem using either the normally open or normally closed contact.

Surge-BLOK | Part Codes



20-2S-S3-2-06-A-HL

Suitable for use on a circuit capable of delivering not more than 200,000 rms symmetrical amperes, 150V maximum, when protected by a RK5 Class fuse, or a circuit breaker rated at 50A or less (2 Port Connection).

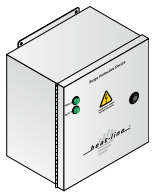

120-2S-M3-3-06-A-HL

Suitable for use on a circuit capable of delivering not more than 200,000 rms symmetrical amperes, 150V maximum, when protected by a 100A RK5 Class fuse.

THE HEAT-LINE TEAM

The Heat-Line team is comprised of professionals from many different industries and backgrounds including tradespeople, engineers, scientists, sale technicians, support staff, and administration personnel. Heat-Line strives to employ individuals that complement the core beliefs of Heat-line through innovative thinking and customer first principles. Every heating cable system manufactured by Heat-Line has been researched, designed and developed internally. As a result the Heat-Line support staff has complete and thorough working knowledge of all the products offered within the Heat-Line product group.



NOTES:



The Most Advanced Freeze Protection Systems in the World

The Heat-Line Difference:

Heat-Line brand products are specifically manufactured to solve issues encountered in extreme cold climates. Industry-leading knowledge and experience, respect for our customers, and attention to detail has generated a loyal following of customers that trust Heat-Line products, and that will never change. Part of respecting and developing a loyal customer base is developing solutions that take into account the concerns and needs of those customers. As a result Heat-Line provides products that are developed by experts within the field, supported by award winning customer service, offer efficient operation, manufactured of only the finest self-regulating heating cable and represent marketing leading quality control.





Head Office and Manufacturing Operations

Heat-Line

1095 Green Lake Road

Algonquin Highlands, Ontario, Canada

K0M 1J1

Tel: (800) 584-4944

(705) 754-4545

Fax: (705) 754-4567

info@heatline.com

Represented by:

Heat-Line, ArcticVent, CARAPACE, MilliAMP, Paladin, Retro-DWS, Retro-FM, Retro-Line and Tandem-Link are trademarks or registered trademarks of Heat-Line Corporation. All other trademarks are the property of their respective owners. Many of these products are protected by numerous patents.

Heat-Line

1095 Green Lake Road
Algonquin Highlands, Ontario,
Canada

K0M 1J1

Tel: (705) 754-4545
(800) 584-4944

Fax: (705) 754-4567
info@heatline.com
www.heatline.com

IMPORTANT: All information in this catalogue, including illustrations, is believed to be reliable. Users, however, should independently evaluate the suitability of each product for their particular application. Heat-Line, a Division of Christopher MacLean Ltd., makes no warranties as to the accuracy or completeness of the information, and disclaims any liability regarding its use. Heat-Line's only obligations are those in the Heat-Line Standard Terms and Conditions of Sale for its products, and in no case will Heat-Line be liable for any incidental, indirect, or consequential damages arising from the sale, resale, use, or misuse of its products. Specifications are subject to change without notice. In addition, Heat-Line reserves the right to make changes—without notification to Buyer—to processing or materials that do not affect compliance with any applicable specification.

Heat-Line is a division of Christopher MacLean Ltd.